







Inside Diameter (I.D.)



Outside Diameter (O.D.)



Minimum Bend Radius



Reinforcement Outside Diameter (R.O.D.)



Maximum Working Pressure



Ferrule / Socket



Weight



**Burst Pressure:** The minimum guaranteed burst pressure of the hose; Equivalent or superior to the minimum requirements of the reference specifications.

**Insert:**



- MF MF2000® Multifit type
- IP MF2000® Interlock Plus type
- SP MF2000® Spiralfit type
- SPGX MF2000® Spiralfit GX type
- IS MF2000® Interlock Super type
- BL MF2000® Blastlock type
- PL MF2000® Push-Lock type



**Working pressure:** The maximum pressure at which correct functioning of the quick coupling is assured. The working pressure is assured in both connected and disconnected states.



**Flow Rate:** The quantity of fluid which passes through a cross section of the quick coupling in a specified unit of time.



**Connection Effort:** The effort required to lock the male insert into the female.



**Oil Spillage:** The quantity of fluid lost from the coupling during the connection/disconnection process.



**Connection/Disconnection under pressure:** Ability to connect and disconnect with the quick coupling under pressure.

**Continuous service:** Refers to the working temperature range

**Max. operating temperature (Intermittent service):** Peaks of temperature of short duration and total cumulative duration lower than 5% of the total service life.

**Recommended fluids:** Fluid types that the hose can convey with excellent / good chemical compatibility.

**Hose service life:** Cumulative duration of time in which the hose is under operative conditions.

DASH SIZE	STANDARD HYDRAULIC HOSES		SAE 100 R5 HOSES	
	DN	inch	DN	inch
-03	5	3/16	-	-
-04	6	1/4	5	3/16
-05	8	5/16	6	1/4
-06	10	3/8	8	5/16
-08	12	1/2	10	13/32
-10	16	5/8	12	1/2
-12	19	3/4	16	5/8
-16	25	1	22	7/8
-20	31	1 1/4	29	1 1/8
-24	38	1 1/2	35	1 3/8
-32	51	2	46	1 13/16
-40	63	2 1/2	60	2 3/8
-48	76	3	-	-
-56	89	3 1/2	-	-
-64	102	4	-	-

### NUT TIGHTENING METHODS

**NOTE:** Torque values provided are always to be considered in DRY conditions - that is, when no oil or lubrication is used on the threads or sealing surfaces.

#### TORQUE WRENCH METHOD

If practicable the use of a suitable, calibrated torque wrench is strongly recommended

1. Screw the fitting by hand on the male fitting / adaptor
2. In the case of a straight fitting, whilst blocking the counter-hex with a standard wrench apply the required torque to the nut
3. In the case of an elbow fitting, block the tail of the fitting with a suitable tool and then apply the required torque to the nut



#### FLATS / ROTATION ANGLE METHOD

If the use of a torque wrench is not possible, the flat rule (or nut rotation angle rule) can be applied.

1. Screw the fitting by hand on the male adaptor until the metal to metal contact between the sealing surfaces is reached
2. Mark the relative position between the nut and the adapter
3. Apply the prescribed number of flats by blocking the counter-hex with a standard wrench (straight fitting) or the tail with a proper tool (elbow fitting)



#### WARNING

Result from flat rule method can be affected from the operator:

- During the start phase different hand tightening to achieve the metal to metal contact can change the start position
- During the final phase marks on nut and adaptor can be not very accurate and the final position can be misread

## TORQUING METHODS

In the following tables the tightening values are given according to one or more of the following methods:

**ASSEMBLY TORQUE** - This is the preferred and most precise method, which should be used whenever possible. Value given is the torque in N.m to be applied using a suitable calibrated torque wrench

**ROTATION ANGLE** - Value is the number of degrees that the nut should be rotated through AFTER metal-to-metal contact is made from finger-tightening

**NUMBER OF FLATS** - Value is the number of flats that the nut should be rotated through AFTER metal-to-metal contact is made from finger-tightening

## NUT TIGHTENING TORQUE VALUES FOR BSP FITTINGS

Size	BSP Thread Size	MANULI BSP FITTINGS WITH O-RING (ISO STYLE A)	MANULI BSP FITTINGS WITHOUT O-RING (ISO STYLE B)
		Assembly Torque* [N.m] <sup>+10</sup> <sub>-0</sub>	Assembly Torque* [N.m] <sup>+10</sup> <sub>-0</sub>
1/4"	G 1/4" -19	20	20
3/8"	G 3/8" -19	38	35
1/2"	G 1/2" -14	55	60
5/8"	G 5/8" -14	60	70
3/4"	G 3/4" -14	90	115
1"	G 1" -11	120	140
1 1/4"	G 1 1/4" -11	190	210
1 1/2"	G 1 1/2" -11	250	290
2"	G 2" -11	300	400

\* **IMPORTANT:** Recommended MRI Torque Values are only applicable for nut tightening in **DRY conditions** (no oil or lubrication on threads and sealing surfaces)

## NUT TIGHTENING TORQUE VALUES FOR ORFS FITTINGS

Size	ORFS Thread Size	MANULI ORFS FITTINGS		
		Assembly Torque* [N.m] <sup>+10</sup> <sub>-0</sub>	Rotation Angle [degrees]	No. of Flats [Flats]
1/4"	9/16" -18	26	45°	3/4
3/8"	11/16" -16	42	45°	3/4
1/2"	13/16" -16	57	60°	3/4
5/8"	1" -14	85	45°	1
3/4"	1 3/16" -12	122	45°	3/4
1"	1 7/16" -12	156	45°	3/4
1 1/4"	1 11/16" -12	200	45°	3/4
1 1/2"	2" -12	256	45°	3/4

\* **IMPORTANT:** Recommended MRI Torque Values are only applicable for nut tightening in **DRY conditions** (no oil or lubrication on threads and sealing surfaces)

**NUT TIGHTENING TORQUE VALUES FOR JIC FITTINGS**

Size	JIC Thread Size	MANULI JIC CRIMPED BACK NUT FITTINGS			MANULI JIC SLIP-ON NUT & THRUST-WIRE FITTINGS
		Assembly Torque* [N.m] <sup>+10</sup> <sub>-0</sub>	Rotation Angle [degrees]	No. of Flats [Flats]	Assembly Torque* [N.m] <sup>+10</sup> <sub>-0</sub>
1/4"	7/16" -20	16	90°	1 1/2	16
3/8"	9/16" -18	28	90°	1 1/2	28
1/2"	3/4" -16	53	120°	2	53
5/8"	7/8" -14	85	120°	2	85
3/4"	1 1/16" -12	119	60°	1	119
1"	1 5/16" -12	147	60°	1	147
1 1/4"	1 5/8" -12	172	60°	1	172
1 1/2"	1 7/8" -12	215	60°	1	215
2"	2 1/2" - 12	332	60°	1	332

\* **IMPORTANT:** Recommended MRI Torque Values are only applicable for nut tightening in **DRY conditions** (no oil or lubrication on threads and sealing surfaces)

**NUT TIGHTENING TORQUE VALUES FOR METRIC FITTINGS**

Metric Thread Size	MANULI DKOL FITTINGS		MANULI DKOS FITTINGS	
	Pipe O.D [mm]	Assembly Torque* [N.m] <sup>+10</sup> <sub>-0</sub>	Pipe O.D [mm]	Assembly Torque* [N.m] <sup>+10</sup> <sub>-0</sub>
M12 x 1.5	6L	13		
M14 x 1.5	8L	23	6S	23
M16 x 1.5	10L	32	8S	32
M18 x 1.5	12L	38	10S	38
M20 x 1.5			12S	45
M22 x 1.5	15L	53	14S	53
M24 x 1.5			16S	59
M26 x 1.5	18L	77		
M30 x 2	22L	100	20S	100
M36 x 2	28L	114	25S	114
M42 x 2			30S	180
M45 x 2	35L	200		
M52 x 2	42L	255	38S	255

\* **IMPORTANT:** Recommended MRI Torque Values are only applicable for nut tightening in **DRY conditions** (no oil or lubrication on threads and sealing surfaces)



**NUT TIGHTENING TORQUE VALUES FOR NPTF-NPSM FITTINGS**

NPTF-NPSM Thread Size	MANULI NPTF MALE MATED WITH NPTF PORT	MANULI NPTF MALE MATED WITH NPSM FEMALE
	Max. Assembly Torque* † [N.m]	Max. Assembly Torque* [N.m]
1/8" -27	20	10
1/4" -18	30	15
3/8" -18	40	20
1/2" -14	55	27
3/4" -14	70	35
1" -11.5	90	45
1 1/4" -11 1/2	100	50
1 1/2" -11 1/2	120	60
2" - 11 1/2	150	75

\* **IMPORTANT:** Recommended MRI Torque Values are only applicable for nut tightening in **DRY conditions** (no oil or lubrication on threads and sealing surfaces)

† If thread sealant is used, maximum values show above should be decreased by 25%

**WARNING:** Compatibility of hose and fittings with conveyed fluid is an essential factor in avoiding chemical reactions that may result in release of fluids or failure of the hose or connection. This chemical compatibility guide must not be used in conjunction with any other compatibility guides from previous or future catalogue editions, bulletins or publications. Incorrect use of these charts could result in personal injury or property damage.

## HOSE SELECTION BY MEDIUM AND HOSE TYPE

This hose compatibility chart is a reference of Manuli Hydraulics hose compatibility with various fluid media. It is intended as a guide to chemical compatibility with inner tube materials and assembly lubricants applied internally to the hose. The Fluid Compatibility Chart lists the relative resistance of hose tube and fitting materials to more common:

- hydraulic oils
- other diversified oils families (for hydrokinetic and lubrication applications)
- chemicals

The ratings shown do not cover all possible variations of all factors, such as temperature, concentration, degradation or fluid contamination, etc. Testing under actual conditions is the best way to assure chemical compatibility for critical applications.

## PART 1: HYDROSTATIC OILS COMPATIBILITY CHART (ACTUAL HYDRAULIC SYSTEMS AND APPLICATIONS)

The specific recommendations regarding **hydraulic fluids** are based upon specific laboratory bench tests with fluids, performed according to ISO 1817 and internal methodology, integrated with field experiences and the advices of various polymers or fluid suppliers. **It must be stressed, however, that this information is offered only as a guide and is not a guarantee.** Final hose selection also depends upon pressure, fluid and ambient temperatures, concentration, duration of exposure and special requirements or variations, which may not be known by Manuli Hydraulics. Legal and other regulations must be followed with particular attention.

All the combined factors in working operations may impact on the service life of the hose assembly and must be carefully considered before releasing a hose for a specific application: the chemical compatibility with the service fluid is only one of the factors to be considered.

It is always recommended to test the specific fluid brand name with the requested hose, in order to verify chemical compatibility. Manuli Hydraulics constantly performs compatibility tests as service to market, progressively updating the compatibility chart.

## PART 2: HYDROKINETIC APPLICATIONS AND LUBRICANT OILS COMPATIBILITY CHART (AUTOMATED TRANSMISSIONS AND VARIOUS LUBRICATION SYSTEMS)

This second part of the compatibility chart list a particular family of oils, not designed for standard hydraulics (hydrostatic applications), rather studied for many diversified applications such as lubrication for gear, compressors, turbines, diathermic oils for cooling or heat transmission, and ATF (Automatic Transmission Fluids) oils for the hydrokinetic (hydrodynamic) applications. These fluids are often very aggressive on traditional tube rubbers, more than hydraulic oils, due to the nature of the fluids and additives, aimed to give properties of long life duration and high temperature resistance; that's why their chemical compatibility with tube rubbers must be carefully checked before eventual use.

**WARNING:** Compatibility of hose and fittings with conveyed fluid is an essential factor in avoiding chemical reactions that may result in release of fluids or failure of the hose or connection. This chemical compatibility guide must not be used in conjunction with any other compatibility guides from previous or future catalogue editions, bulletins or publications. Incorrect use of these charts could result in death, personal injury or property damage.

It is to be underlined that Manuli hoses are designed in principle for use with hydraulic oils only, and that diversified applications such as the ones with these categories of other oils, must be verified case by case with lab and/or field tests by users under their sole and exclusive responsibility and no liability whatsoever can be attributed to Manuli Hydraulics in that regard.

For more detailed information contact Manuli Hydraulics or visit [www.manuli-hydraulics.com](http://www.manuli-hydraulics.com)

### **PART 3: BEHAVIOUR TO CHEMICALS (GUIDELINES FROM LITERATURE) FOR NON-HYDRAULIC APPLICATIONS**

**WARNING: Manuli hoses are designed for hydraulics use and applications, they are not intended for industrial diversified applications with various chemicals.**

The recommendations regarding generic chemicals are mainly based on literature data in conjunction with polymers used for the tube compound. The field results of the fluid conveyed in the hose should be carefully tested and field validated by users.

No test on finished hose assemblies in combination with the mentioned chemicals has been normally performed.

**The possible good rating and on field performance of the hose with a chemical mentioned in the list does not mean in any case the release by Manuli Hydraulics of the product for that application or any guarantee. The possible validation for use is under the sole and exclusive responsibility of the end user and no liability whatsoever can be attributed to Manuli Hydraulics in that regard. In fact Manuli Hydraulics hoses are designed for hydraulics use and applications, they are not intended for industrial diversified applications with various chemicals.**

The outer cover of the hose is intended to protect the reinforcement layer(s) from mechanical influences (abrasion, weathering etc.); cover compounds are not designed to exhibit the same chemical resistance as the tube compounds. Manuli Hydraulics should be consulted about the compatibility of the cover, should the application involve the extended exposure or immersion in a liquid: **anyway the hydraulic hoses of the Manuli Hydraulics product range are not designed in general for immersion in the service fluid.**

This type of special applications should be avoided or carefully studied with additional external protections for the hoses, selection of special hose types, e.g. with thermoplastic cover and validation on the specific application. The turbulence of the fluid, the high temperature and nature of the fluid as well as other elements may impact the properties or integrity of the hose cover material (the cover compound of the hose is designed to resist to oil drops and external agents, not immersion in the service fluid).

For more detailed information contact Manuli Hydraulics or visit [www.manuli-hydraulics.com](http://www.manuli-hydraulics.com)

**WARNING: No tests on finished hose assemblies in combination with the mentioned chemicals has been normally performed. The possible good rating and on field performance of the hose with a chemical mentioned in the list, does not mean in any case the release by Manuli Hydraulics of the product for that application or any guarantee. The possible validation for use is under the sole and exclusive responsibility of the end user and no liability whatsoever can be attributed to Manuli Hydraulics in that regard. In fact Manuli Hydraulics hoses are designed for hydraulics use and applications, they are not intended for industrial diversified applications with various chemicals. No tests on finished hose assemblies in combination with the mentioned chemicals has been normally performed.**

**WARNING: Compatibility of hose and fittings with conveyed fluid is an essential factor in avoiding chemical reactions that may result in release of fluids or failure of the hose or connection. This chemical compatibility guide must not be used in conjunction with any other compatibility guides from previous or future catalogue editions, bulletins or publications. Incorrect use of these charts could result in death, personal injury or property damage.**

## LEGEND OF THE HOSE TYPES BY TUBE COMPOUNDS

TUBE COMPOUND CATEGORIES	HOSE CATEGORIES	HOSE TYPES
NITRILE	STD WIRE BRAID	ROCKMASTER, HARVESTER/17, SHIELDMASTER, GOLDENISO, COVER, CRYOFLEX
NITRILE	STD WIRE SPIRAL	ROCKMASTER, GOLDENISO, SHIELDMASTER, ANACONDA, FOREMASTER, CRYOFLEX, DIAMONDSPIR, XTRAFLOW/4WS, HYDROROPE, HERCULES
NITRILE	HI-PER WIRE BRAID	FOREMASTER, GOLDENISO/PILOT, ROCKMASTER/1SC, SYNERGY, INFINITY
NITRILE	TEXTILE REINF.	ASTRO, SPIRTEX, MULTITEX, PUSHFIT
CHLOROPRENE		ETERNITY/2, /2K, GOLDENBLAST
CHLOROSULPHONATED POLYETHYLENE		EQUATOR/1 (BLUE & BLACK), EQUATOR/2 (BLUE & BLACK), XTRAFLOW/HT
CHLORINATED POLYETHELENE		MASTERTEX
POLYESTER		HYDROPLAST, HYDROTWIN

## HOW TO USE THE CHART

- Hydraulic fluids are listed in alphabetic order with the manufacturer brand name and ISO identification symbol (DIN when available), chemicals are listed alphabetically
- Find the hose type and read the compatibility rating (see rating scale)
- Define the proper hose selection for the application by choosing the best rating

## LEGEND OF RATINGS

**E = Excellent** - Small or negligible changes of compound properties: no problem for use. Service life can exceed the expectations.

**G = Good** - There are only minor changes of some compound properties. Service life is normally in line with state of the art (standard) expectations.

**FT = Field Test recommended** - A field test is recommended to allow the end user to either validate the selection in the actual working conditions or to reject the selection. Results of compatibility from lab testing show significant changes on some compound properties, service life can be reduced. Higher durability can be achieved with reduced severity of working conditions (temperature in particular) or with an upgraded hose selection. After the results of the recommended field test, if the end user decides to use the selected hoses under his validation, the end users assumes all responsibility with regard to any possible effects and consequences arising out of the using of hoses in the actual working conditions and Manuli Hydraulics cannot be held responsible for any claims in relation to or connected with the hoses for which it was recommended to perform a field test.

**X = Not recommended** - Unsuitable, severe effects on physical properties.

## REMARKS

O-Rings used with couplings must also be considered for chemical compatibility with the fluid to be conveyed. This includes fittings containing internal O-Rings; for example Metric Female 24° Cone seat fittings, etc. Standard O-Ring of Manuli Hydraulics fittings are made of Nitrile rubber (NBR), highly chemically compatible with all hydraulic fluids. If you use special fluids or very high temperatures, different O-Ring materials should be used, contact Manuli Hydraulics for specific information. See Technical Manual for dimensions of O-Rings.

Compatibility of hose fittings with conveyed fluids is an essential factor in avoiding chemical reactions that may result in release of fluids and failure of the connection with the potential of causing severe personal injury or property damage. Standard Manuli Hydraulics fittings are made of carbon steel with Hexavalent chromium free plating.

**WARNING:** Compatibility of hose and fittings with conveyed fluid is an essential factor in avoiding chemical reactions that may result in release of fluids or failure of the hose or connection. This chemical compatibility guide must not be used in conjunction with any other compatibility guides from previous or future catalogue editions, bulletins or publications. Incorrect use of these charts could result in death, personal injury or property damage.

## OILS CLASSIFICATION - ACCORDING TO ISO 6743-4

ISO 6743-4 is an important norm regarding “Lubricants, industrial oils and related products (class L)”. The norm defines a very wide family of oils, used in many different sectors and applications.

The oils must be carefully understood and properly managed to avoid problems and possible mistakes. The Part 4 of the norm in particular regards the Hydraulic Oils (Family H), for hydrostatic and hydrokinematic applications, the other parts of the norm regard other fluids, of different nature or aimed to different applications than hydraulics.

Manuli Hydraulics hoses are designed and qualified for use with Hydraulic Oils (Family H of the ISO 6743-4), and the behaviour of the particular oil formulation has to be verified case by case.

The applications with oils of the families different than H must be checked carefully but in principle Manuli Hydraulics hoses are not designed for use with them.

Here below the classification of oils by ISO 6743 spec.

Part 1: Family A (Total Loss systems)

Part 2: Family F (Spindle bearings, bearings and associated clutches)

Part 3A: Family D (Compressors)

Part 3B: Family D (Gas and refrigeration compressors)

### **Part 4: Family H (Hydraulic Systems)**

Part 5: Family T (Turbines)

Part 6: Family C (Gears)

Part 7: Family M (Metalworking)

Part 8: Family R (Temporary protection against corrosion)

Part 9: Family X (Greases)

Part 10: Family Y (Miscellaneous)

Part 11: Family P (Pneumatic tools)

Part 12: Family Q (Heat Transfer Fluids)

Part 13: Family G (Slideways)

Part 14: Family U (Heat treatment)

Part 15: Family E (Internal combustion engines)

Part 99: General

**WARNING:** Compatibility of hose and fittings with conveyed fluid is an essential factor in avoiding chemical reactions that may result in release of fluids or failure of the hose or connection. This chemical compatibility guide must not be used in conjunction with any other compatibility guides from previous or future catalogue editions, bulletins or publications. Incorrect use of these charts could result in death, personal injury or property damage.

The Family H in particular, object of use with Manuli Hydraulics hoses is composed by the following families of oils, identified by ISO dedicated symbols, used also in the compatibility chart.

GENERAL APPLICATION	PARTICULAR APPLICATION	MORE SPECIFIC APPLICATIONS	COMPOSITION AND PROPERTIES	SYMBOL ISO-L
<b>HYDRAULIC SYSTEMS</b>	<b>HYDROSTATIC APPLICATIONS</b>	(STD HYDRAULIC APPLICATIONS)	NON-INHIBITED REFINED MINERAL OILS	HH
			REFINED MINERAL OILS WITH IMPROVED ANTI-RUST AND ANTI-OXIDATION PROPERTIES	HL
			OILS OF HL TYPE WITH IMPROVED ANTI-WEAR PROPERTIES	HM
			OILS OF HM TYPE WITH IMPROVED VISCOSITY/TEMPERATURE PROPERTIES	HV
		APPLICATIONS WHERE ENVIRONMENTALLY ACCEPTABLE FLUIDS ARE REQUESTED	TRIGLYCERIDES	HETG
			POLYGLYCOLS	HEPG
			SYNTHETIC ESTERS	HEES
			POLYALPAOLEFIN AND RELATED HYDROCARBON PRODUCTS	HEPR
		HYDRAULIC SLIDE-WAY SYSTEMS	OILS OF HM TYPE WITH ANTI-STICK/SLIP PROPERTIES	HG
			OILS IN WATER EMULSION	HFAE
			CHEMICAL SOLUTION IN WATER	HFAS
			WATER IN OIL EMULSION	HFB
			WATER POLYMER SOLUTIONS	HFC
			SYNTHETIC FLUIDS CONTAINING NO WATER AND CONSISTING OF PHOSPHATE ESTERS	HFDR
			SYNTHETIC FLUIDS CONTAINING NO WATER AND OF OTHER COMPOSITION	HFDU

XXX

GENERALLY GOOD COMPATIBILITY WITH HOSES, ANYWAY THE BEHAVIOUR OF THE PARTICULAR OIL FORMATION TO BE VERIFIED CASE BY CASE

HFAS & HFDR

NO COMPATIBILITY WITH MANULI HYDRAULICS HOSES. DEDICATED HOSES ARE REQUESTED

**NOTE:** ATF OILS ARE NOT CLASSIFIED AS HYDRAULIC OILS

**WARNING:** Compatibility of hose and fittings with conveyed fluid is an essential factor in avoiding chemical reactions that may result in release of fluids or failure of the hose or connection. This chemical compatibility guide must not be used in conjunction with any other compatibility guides from previous or future catalogue editions, bulletins or publications. Incorrect use of these charts could result in death, personal injury or property damage.

**PART 1: HYDROSTATIC APPLICATION OILS COMPATIBILITY CHART**

**(ACTUAL HYDRAULIC SYSTEMS AND APPLICATIONS)**

HYDRAULIC FLUID	TYPE		WIRE SPIRAL	WIRE BRAID				TEXTILE BRAID	TPE TEXTILE BRAID
	ISO 6743-4	DIN 51524	ROCKMASTER GOLDENISO SHIELDMASTER ANACONDA FOREMASTER CRYOFLEX DIAMONDSPIR XTRAFLOW/4WS HYDROROPE HERCULES	ETERNITY/2	ROCKMASTER HARVESTER/17 SHIELDMASTER GOLDENISO COVER CRYOFLEX	FOREMASTER GOLDENISO/PILOT ROCKMASTER/1SC SYNERGY INFINITY	EQUATOR XTRAFLOW/HT	ASTRO SPIRITEX MULTITEX PUSH FIT	HYDROPLAST HYDROTWIN
ACT ECOSAFE FR 46	HFDU	-	E	E	FT	G	FT	G	-
ACT FR WG 200 D	HFC	-	E	X	E	-	X	E	-
ADDINOL ÖKOSYNTH SUPER HEES 46	HEES	-	G	FT	G	G	FT	G	-
ADDINOL ÖKOSYNTH SUPER HEES 46 S	HEES	-	G	FT	G	G	FT	G	-
AGIP ARNICA 46	HV	HVLP	E	G	G	G	E	G	-
AGIP ARNICA EXTRA PLUS	HEES	HVLP	G	G	G	G	FT	G	E
AGIP ARNICA PLUS	HEES	HVLP	E	E	G	G	FT	E	E
AGIP ARNICA S46	HFDU	-	E	E	G	G	FT	E	E
AGIP OSO 32	HM	HLP	E	E	G	G	E	E	G
AGIP OSO 46 S	HM	HLP	E	G	G	G	G	G	G
AGIP OSO D 46	HM	HLPD	G	G	G	E	G	G	-
AGROL MENDO 46	HEES	-	-	FT	-	-	FT	-	-
AKZO FYRQUEL	HFDR	-	X	X	X	X	-	X	-
AMBRA HITECH 46	HL	HLP	E	E	G	G	G	E	G
ANDEROL 8768 (PAO)	HEPR	-	G	G	FT	FT	FT	G	-
API HS 46	HV	HVLP	E	G	G	G	E	-	-
ARAL VITAM EHF 46	HEES	-	E	E	G	G	G	G	G
ARAL VITAM GF 68	HL	HLP	E	E	E	G	E	E	E
AVIA AVILUB HLP 546	HM	HVLP	G	G	G	G	E	G	-
AVIA AVILUB SF 568	HM	HLP	-	-	-	-	G	-	-
AVIA BIOFLUID BP 32	HEES	-	G	FT	G	E	X	G	-
AVIA FLUID RSL 32	HS	-	E	G	G	G	-	-	-
AVIA FLUID RSL 68	HM	HLP	G	G	G	G	E	G	-
AVIA HVI 46	HV	HVLPD	G	G	G	G	E	G	-
AVIA SYNTOFLUID F 46	HEES	-	E	G	E	G	G	G	E
AVIA SYNTOFLUID N 32	HEES	-	G	G	E	G	G	E	G
AVIA SYNTOFLUID N 46	HEES	-	E	E	G	G	G	E	G
AVIA SYNTOFLUID PE B 30 (PAO)	HEPR	-	E	G	G	G	G	G	G
AVIA SYNTOFLUID PE B 50 (PAO)	HEPR	-	E	E	G	G	G	G	-
BASF PLURASAFE XTREME FR HYD FLUID	HFDR	-	X	X	X	X	X	X	X
BECHEM HYDROSTAR PM 46	HH	-	E	E	G	-	G	E	-
BINOL HYDRA P 1146	HETG	-	E	E	G	G	-	G	-
BP A 0629L/028	HS	-	G	FT	G	G	E	G	G

**WARNING:** Compatibility of hose and fittings with conveyed fluid is an essential factor in avoiding chemical reactions that may result in release of fluids or failure of the hose or connection. This chemical compatibility guide must not be used in conjunction with any other compatibility guides from previous or future catalogue editions, bulletins or publications. Incorrect use of these charts could result in death, personal injury or property damage.

HYDRAULIC FLUID	TYPE		WIRE SPIRAL	WIRE BRAID				TEXTILE BRAID	TPE TEXTILE BRAID
	ISO 6743-4	DIN 51524	ROCKMASTER GOLDENISO SHIELDMASTER ANACONDA FOREMASTER CRYOFLEX DIAMONDSPIR XTRAFLOW/4WS HYDROROPE HERCULES	ETERNITY/2	ROCKMASTER HARVESTER/17 SHIELDMASTER GOLDENISO COVER CRYOFLEX	FOREMASTER GOLDENISO/PILOT ROCKMASTER/15C SYNERGY INFINITY	EQUATOR XTRAFLOW/HT	ASTRO SPIRTEX MULTITEX PUSH FIT	HYDROPLAST HYDROTWIN
BP BARTRAN HV	HV	HVLP	E	G	G	G	E	G	-
BP BIOHYD SE-S 46	HEES	-	G	G	E	G	FT	E	-
BP ENERGOL HLP 46	HL	HLP	G	G	G	-	-	-	-
BREMER & LEGUIL RIVOLTA SBH 11	HEES	-	G	FT	E	G	X	G	G
BREMER RIVOLTA SBH 23	HEES	-	E	G	E	G	G	G	E
CALTEX RANDO DSZ 46	HV	HVLP	G	G	FT	G	G	FT	-
CALTEX RANDO HD	HM	HLP	E	G	G	G	G	G	G
CALTEX RANDO HD LVZ 46	HV	HVLP	G	G	G	G	G	FT	-
CASTROL AERO HF 585 B (MIL 56006H)	HH	HL	E	FT	G	-	FT	E	FT
CASTROL ANVOL SWX 68 (POE BASED)	HFDU	-	E	FT	E	-	FT	G	-
CASTROL BIOBAR VG 68	HEES	-	E	FT	E	E	X	G	-
CASTROL BIOTECH ALPIN 22	HETG	-	E	E	E	-	FT	E	-
CASTROL BRAYCO 717 (MIL 17111C)	HS	-	G	FT	G	-	FT	G	G
CASTROL BRAYCO MICRONIC 882	HH	HL	G	G	G	G	G	G	G
CASTROL CARELUBE HTG	HETG	-	E	FT	E	E	FT	E	G
CASTROL CARELUBE HY 46	HEES	-	G	G	G	G	FT	G	G
CASTROL HYSPIIN HDH 7000	HM	-	E	G	G	-	E	E	-
CASTROL HYSPIIN HLPD 46	HM	HLP	-	E	G	G	G	G	G
CASTROL HYSPIIN HVI 46 D	HV	HLPD	E	G	G	G	G	G	G
CASTROL HYSPIIN ZZ32	HM	HLP	G	G	G	G	E	G	G
CASTROL ILOCUT 546 MP	HM	-	-	G	G	G	E	G	-
CASTROL LIFT OIL	HH	HL	G	G	G	G	G	G	G
CASTROL PRODUCT L 320	HH	HL	E	G	G	-	X	G	-
CASTROL PRODUCT L 571	HH	HL	E	G	G	G	X	G	-
CASTROL TRIBOL HM 943-46	HM	-	G	G	G	G	G	-	-
CAT HYDO ADVANCE 10	HM	-	E	E	G	G	G	-	-
CENEX INDOL PREMIUM AW 4646	HM	HLP	G	E	G	G	-	G	-
CEPSA HYDRAULICO HM 46	HM	HLP	E	E	G	-	E	G	E
CHEVRON ETL 10328	HV	HVLP	G	E	G	G	G	G	-
CHEVRON EXTRA HYD OIL VG 46	HM	-	G	G	G	G	FT	-	-
CHEVRON HYDRAULIC AW 46	HM	HLP	E	G	G	G	E	G	-
CHEVRON MACHINE OIL AW 220	HV	HLP	G	G	G	G	G	G	G
CHEVRON MACHINE OIL AW ISO 46	HV	HLP	G	G	G	G	G	G	G
CHEVRON RANDO HD 68	HM	HLP	G	G	G	G	G	G	-
CHEVRON RYCON MV	HM	-	E	G	G	G	G	G	-
COAST OIL A/W 68	HM	-	G	G	G	-	G	-	-

**WARNING:** Compatibility of hose and fittings with conveyed fluid is an essential factor in avoiding chemical reactions that may result in release of fluids or failure of the hose or connection. This chemical compatibility guide must not be used in conjunction with any other compatibility guides from previous or future catalogue editions, bulletins or publications. Incorrect use of these charts could result in death, personal injury or property damage.



HYDRAULIC FLUID	TYPE		WIRE SPIRAL	WIRE BRAID				TEXTILE BRAID	TPE TEXTILE BRAID
	ISO 6743-4	DIN 51524	ROCKMASTER GOLDENISO SHIELDMASTER ANACONDA FOREMASTER CRYOFLEX DIAMONDSPIR XTRAFLOW/4WS HYDROROPE HERCULES	ETERNITY/2	ROCKMASTER HARVESTER/17 SHIELDMASTER GOLDENISO COVER CRYOFLEX	FOREMASTER GOLDENISO/PILOT ROCKMASTER/1SC SYNERGY INFINITY	EQUATOR XTRAFLOW/HT	ASTRO SPIRTEX MULTITEX PUSH FIT	HYDROPLAST HYDROTWIN
CONDAT D 46	HFDU	-	E	FT	G	-	FT	G	-
CONOCO ECOTERRA	HM	HLP	G	G	FT	FT	G	-	-
DEA ECONA E 46	HEES	-	G	FT	E	G	FT	E	E
DOMUS FLUID 46	HEES	-	G	G	G	G	-	G	G
DOT 3	HPG	-	-	-	X	X	X	X	G
DOT 4	HPG	-	-	-	X	X	X	X	G
ELAN HYDRAULIC 46	HV	HVLP	E	G	G	G	E	G	G
ESSO HYDRAULIKOEL HE 46	HEES	-	E	E	E	G	G	E	E
ESSO NUTO H46	HM	HLP	G	G	G	G	E	G	E
EUROLUB HLP 46	HM	-	G	G	FT	G	G	-	-
EXXON HUMBLE H 46	HM	HLP	E	G	G	G	E	G	-
EXXON RL 002775B	HM	-	G	G	G	G	FT	-	-
EXXON UNIVIS N46	HV	HVLP	E	G	G	G	E	G	-
FINKE AVIATICON HY HE	HEES	-	G	G	E	-	-	E	G
FOLTZERMSRINGOLI HYDRA 46	HH	-	G	G	G	G	E	G	-
FRAGOLHE 46	HEES	-	E	FT	G	-	FT	G	E
FUCHS AQUACENT LT 68	HFB	-	G	FT	G	G	FT	G	-
FUCHS ECO HYD 46S NWG	HEES	-	G	FT	G	-	X	G	-
FUCHS OM 13	HH	HL	G	G	G	-	G	E	E
FUCHS OM 65	HH	HL	G	G	G	-	-	G	G
FUCHS PLANTOHYD 46S	HEES	-	E	FT	E	G	FT	E	E
FUCHS PLANTOHYD N 46	HETG	-	G	FT	E	G	FT	E	E
FUCHS PLANTOHYD SUPER S46	HEES	-	G	X	E	G	X	-	-
FUCHS PLANTOSYN 3268 ECO	HEES	-	G	FT	E	G	G	E	G
FUCHS PLANTOSYN 46 HVI	HEES	-	E	FT	G	-	FT	G	G
FUCHS RENOLIN B 46 HVI	HV	HVLP	E	G	G	G	E	G	G
FUCHS RENOLIN B15 VG46	HV	HVLP'	G	G	G	-	-	-	-
FUCHS RENOLIN D15 VG 46	HM	HLPD	E	G	G	G	-	G	-
FUCHS RENOLIN MINE AW 68	HM	-	G	G	FT	G	-	-	G
FUCHS RENOLIN MR 520	HV	HVLPD	G	G	G	G	G	E	E
FUCHS TITAN H 46	HV	HVLP	G	G	G	G	G	G	G
FUCHS TITAN HV 68	HV	HVLP	G	G	G	G	G	G	G
GULF ARMONY AW 46	HM	HLP	E	E	G	G	E	G	E
HOUGHTON COSMOLUBRIC HF 130 (POE BASED)	HFDU	-	G	G	G	-	FT	G	-
HOUGHTON HYDRAVIS BC 84005 (60°C)	HFC	-	E	G	E	G	FT	E	E
HOUGHTON ISOCORE E 68 PLUS	HFC	-	E	G	E	-	FT	G	-
HOUGHTON SAFE 620	HFC	-	G	G	G	-	X	-	-

**WARNING:** Compatibility of hose and fittings with conveyed fluid is an essential factor in avoiding chemical reactions that may result in release of fluids or failure of the hose or connection. This chemical compatibility guide must not be used in conjunction with any other compatibility guides from previous or future catalogue editions, bulletins or publications. Incorrect use of these charts could result in death, personal injury or property damage.

HYDRAULIC FLUID	TYPE		WIRE SPIRAL	WIRE BRAID				TEXTILE BRAID	TPE TEXTILE BRAID
	ISO 6743-4	DIN 51524	ROCKMASTER GOLDENISO SHIELDMASTER ANACONDA FOREMASTER CRYOFLEX DIAMONDSPIR XTRAFLOW/4WS HYDROROPE HERCULES	ETERNITY/2	ROCKMASTER HARVESTER/17 SHIELDMASTER GOLDENISO COVER CRYOFLEX	FOREMASTER GOLDENISO/PILOT ROCKMASTER/15C SYNERGY INFINITY	EQUATOR XTRAFLOW/HT	ASTRO SPIRTEX MULTITEX PUSH FIT	HYDROPLAST HYDROTWIN
HOUGHTON SAFE OX 40	HFC	-	E	G	E	G	FT	E	E
HOUGHTON VITAL FLUID L46AL	HFDU	-	G	G	E	G	FT	-	-
HOUGHTON-SAFE 273 CTF	HFC	-	E	FT	E	G	X	E	E
IDEMITSU DAPHNE 46	HH	HL	G	G	G	G	G	G	-
IDEMITSU SUPER HYDRO 28XT-B	HM	HLP	E	E	G	G	E	G	G
IGOL MATIC ZNS 46	HV	-	E	G	G	-	E	-	-
IGOL TICMA FLUID	HV	-	E	G	G	-	E	G	-
IGOL TICMA FLUID BIO 46	HEES	-	G	G	G	-	FT	G	-
INGERSOLL RAND SSR ULTRACOOOLANT (POLYGLICOLE COMP. COOLANT)	HEPG	-	G	G	G	G	G	G	-
INGERSOLL RAND TECHTROL GOLD(POLYGLICOLE COMP. COOLANT)	HEPG	-	G	FT	G	G	G	G	-
IRVING HYDRAULICS 46	HM	HLP	G	G	G	-	E	G	-
JCB OPTIMUM PERFORMANCE HYD OIL 46	HV	HVLP	G	E	G	G	G	G	G
JIANGSU GAOKE L-HM32	HM	HLP	-	-	G	-	E	-	-
JOHN DEERE BIO GUARD II	HETG	-	E	E	E	G	E	G	G
KENDALL HYKEN GLACIAL BLUE HYD FLUID	HV	-	G	FT	G	G	FT	G	G
KLUBER HYSYN FG46	HS	-	G	G	FT	FT	G	FT	-
KLUBER KLUBERBIO EG 2-100	HEES	-	G	G	G	G	-	G	-
KLUBER KLUBERBIO EG 2-68	HEES	-	G	G	G	G	-	G	-
KLUBER KLUBERBIO LR 9 68	HEES	-	E	FT	G	G	X	G	-
KLUBERFOOD 4 NH1 46	HM	HLP	G	FT	FT	-	FT	FT	-
KOMATSU GENUINE BIO 46 G4	HEES	-	E	G	G	G	G	G	E
KOMATSU KPO 10 POWERTRAIN TO 10	HH	-	E	E	G	E	G	G	E
KUNLUN LHM 46	HM	HLP	E	G	G	G	E	G	G
LIEBHERR HYD BASIC 68	HM	HLPD	E	G	G	-	-	-	-
LIEBHERR HYDRAULIC HVI	HV	HVLPD	E	G	G	G	-	G	-
LIEBHERR HYDRAULIC PLUS	HEPR	HVLPD	G	G	G	G	-	-	-
LIEBHERR HYDRAULIC PLUS ARCTIC	HEPR	HVLPD	E	E	G	-	-	-	-
LUKOIL GEYSER ST	HM	-	E	G	G	G	E	G	G
LUKOIL GEYSER ZF	-	HLP	G	G	G	G	E	G	G
MACDERMID OCEANIC BTC 181	HS	-	E	G	G	G	-	G	G
METLUBE HFR 220	HFDU	-	G	G	G	G	E	FT	-
MICRO QUIMICA MICROCORTE 530	HFB	-	FT	X	FT	-	X	FT	-
MILLERS MILLFOOD 32	HS	-	G	G	G	-	E	G	E
MILLERS MILLMAX 22	HM	-	E	G	G	G	G	G	-

**WARNING:** Compatibility of hose and fittings with conveyed fluid is an essential factor in avoiding chemical reactions that may result in release of fluids or failure of the hose or connection. This chemical compatibility guide must not be used in conjunction with any other compatibility guides from previous or future catalogue editions, bulletins or publications. Incorrect use of these charts could result in death, personal injury or property damage.

HYDRAULIC FLUID	TYPE		WIRE SPIRAL	WIRE BRAID				TEXTILE BRAID	TPE TEXTILE BRAID
	ISO 6743-4	DIN 51524	ROCKMASTER GOLDENISO SHIELDMASTER ANACONDA FOREMASTER CRYOFLEX DIAMONDSPIR XTRAFLOW/4WS HYDROROPE HERCULES	ETERNITY/2	ROCKMASTER HARVESTER/17 SHIELDMASTER GOLDENISO COVER CRYOFLEX	FOREMASTER GOLDENISO/PILOT ROCKMASTER/1SC SYNERGY INFINITY	EQUATOR XTRAFLOW/HT	ASTRO SPIRTEX MULTITEX PUSH FIT	HYDROPLAST HYDROTWIN
MOBIL AERO HF 46 (MIL 5606H)	HH	HL	E	G	G	-	FT	G	-
MOBIL DTE 10 EXCEL 46	HV	HVLP	G	E	G	G	FT	G	-
MOBIL DTE 10 EXCEL 68	HV	HVLP	G	G	G	G	FT	-	-
MOBIL DTE 13	HV	HVLP	E	G	G	-	E	G	-
MOBIL DTE 24	HV	HVLP	G	G	G	G	E	G	-
MOBIL DTE 25	HV	HVLP	E	G	G	G	E	G	E
MOBIL DTE 25 ULTRA	HV	HVLP	G	E	G	E	G	G	G
MOBIL DTE 26	HV	HVLP	G	G	G	-	E	FT	E
MOBIL DTE EXCEL 46	HM	HLP	E	E	G	G	E	G	G
MOBIL DTE EXCEL 68	HM	HLP	G	-	G	G	E	-	-
MOBIL DTE FM 32	HM	-	E	G	G	-	G	G	-
MOBIL EAL 224 H	HETG	-	G	G	E	G	-	E	G
MOBIL HYDROFLUID HFDU	HFDU	-	E	E	E	E	G	E	E
MOBIL SHC 524	HM	-	E	G	G	G	E	-	-
MOBIL SHC CIBUS 46	HV	HVLP	G	G	G	G	G	G	-
MOBIL UNIVIS N 46	HV	HVLP	E	G	G	G	G	G	G
MORRIS TRIAD 32	HM	-	-	G	G	G	G	-	-
MOTOREX ALPINE COREX POLAR S370	HV	HVLP	G	FT	FT	G	FT	G	-
MOTOREX COREX HV 22	HM	-	E	G	G	G	E	G	G
MOTOREX COREX HV 46	HM	-	G	E	G	G	G	-	-
MOTOREX COREX HW	HV	HVLP	E	G	G	E	E	E	G
MOTOREX OEKOSYNTH HEES 46	HEES	-	G	X	G	G	X	G	-
MOTUL SHOCK OIL VI 400	HEES	-	G	FT	G	G	X	G	-
NALCO VARIDOS FSK 40%	HFB	-	E	G	E	E	FT	E	-
NESTE BIO HYDRAULI LONGLIFE 46	HEES	-	G	FT	G	G	FT	G	-
NESTE BIO HYDRAULI SE 46	HEES	-	G	FT	G	G	FT	G	-
NESTE BIO HYDRAULI SE 46 PLUS	HEES	-	E	G	E	E	FT	G	G
NESTE HYDRAULI 32 SUPER	HV	HVLP	E	G	G	G	E	-	-
NESTE HYDRAULI 46 SUPER	HV	HVLP	E	G	G	G	E	-	-
NESTE HYDRAULI 68 SUPER	HV	HVLP	G	E	G	G	E	G	E
NEW PROCESS AG NP HYD OIL PC HV1 46	HV	HVLP	-	FT	FT	G	G	-	-
NOALOIL IDRO 32	-	HLP	E	G	G	-	E	G	G
NYCO HYDRAULIC OIL FH 3 (MIL H 46170 C-1)	HH	HL	E	G	G	G	E	G	-
NYCO HYDRAULIC OIL FH 51 (MIL 5606H)	HH	HL	E	G	G	G	FT	G	-
NYCO HYDRAULIC OIL FH 6 (MIL 6083H)	HH	HL	G	G	E	-	FT	E	FT

**WARNING:** Compatibility of hose and fittings with conveyed fluid is an essential factor in avoiding chemical reactions that may result in release of fluids or failure of the hose or connection. This chemical compatibility guide must not be used in conjunction with any other compatibility guides from previous or future catalogue editions, bulletins or publications. Incorrect use of these charts could result in death, personal injury or property damage.

HYDRAULIC FLUID	TYPE		WIRE SPIRAL	WIRE BRAID				TEXTILE BRAID	TPE TEXTILE BRAID
	ISO 6743-4	DIN 51524	ROCKMASTER GOLDENISO SHIELDMASTER ANACONDA FOREMASTER CRYOFLEX DIAMONDSPIR XTRAFLOW/4WS HYDROROPE HERCULES	ETERNITY/2	ROCKMASTER HARVESTER/17 SHIELDMASTER GOLDENISO COVER CRYOFLEX	FOREMASTER GOLDENISO/PILOT ROCKMASTER/19C SYNERGY INFINITY	EQUATOR XTRAFLOW/HT	ASTRO SPIRTEX MULTITEX PUSH FIT	HYDROPLAST HYDROTWIN
OEST DOPP-SYNTH 60	HLP	-	G	X	G	G	X	G	-
OEST DOPP-SYNTH 70	HLP	-	G	X	G	-	X	G	-
OMD 90	HH	HL	G	G	G	-	-	G	G
OMV BIOHYD MS 46 (100°C)	HEES	-	G	G	G	G	-	G	G
OMV HLP AL 46	HL	HLP	E	G	FT	-	E	FT	-
OMV HLP M32	HV	HVLP	G	G	G	E	-	G	-
OMV HYD HLP M15	HV	HVLP	E	FT	G	G	-	G	-
PANOLIN EP GEAR SYNTH 30 VDT	HEES	-	G	X	G	G	X	G	G
PANOLIN GRO SYNTH 46	HEES	-	G	FT	G	G	FT	-	E
PANOLIN HLP SYNTH 15	HEES	-	G	X	X	X	X	G	-
PANOLIN HLP SYNTH 32	HEES	-	G	X	G	G	X	G	-
PANOLIN HLP SYNTH 46	HEES	-	E	FT	G	G	X	G	G
PANOLIN HLP SYNTH E 46	HEES	-	E	FT	G	G	X	G	E
PANOLIN HLP UNI 46	HV	HVLP	E	G	G	G	G	G	-
PANOLIN ORCON HYD 46	HV	HVLP	G	G	G	G	G	G	-
PANOLIN TRAFOSYNTH 2	HEES	-	G	X	G	-	X	G	-
PENTOSIN CHF 11 S (POWER STEERING)	HS	-	E	G	G	G	E	G	-
PETRO CANADA HYDREX AW 46	HM	HLP	E	G	G	G	FT	FT	-
PETRO CANADA HYDREX MV 60	HV	HVLP	E	E	G	G	FT	G	-
PETROCANADA HYDREX XV	HV	HVLP	G	G	FT	G	FT	-	-
PETROCANADA SYNTHETIC AW 46	HM	HLP	G	G	FT	G	G	-	-
PETROFER ULTRA SAFE 620	HFC	-	G	G	E	G	X	E	-
PFINDER APRESOL	HH	-	G	G	G	-	E	G	E
Q8 HANDEL 46	HV	HVLP	E	G	G	E	G	E	-
Q8 HANDEL 68	HV	HVLP	G	G	G	-	E	G	E
Q8 HAYDN 32	HM	HLP	E	G	G	G	E	G	-
Q8 HAYDN 46	HM	HLP	E	G	G	E	G	-	-
Q8 HELLER 46	HV	HVLP	E	G	G	-	E	G	-
Q8 HINDEMITH LT	HV	HVLP	G	FT	G	G	FT	G	-
Q8 HOGARTH 46	HV	HVLP	G	G	G	G	G	G	-
Q8 HOLBEIN ECO 46	HV	HVLP	E	G	E	E	G	G	-
Q8 HOLBEIN NWG 32	HEES	-	G	FT	G	-	X	G	-
Q8 HUMMEL 46	HM	HLP	E	E	G	-	G	-	-
QUAKER GREENSAVE N 40	HETG	-	G	G	G	-	FT	G	G
QUAKER QUINTOLUBRIC 888	HFDU	-	G	G	G	G	FT	G	-
QUAKER QUINTOLUBRIC 888-46	HFDU	-	G	FT	G	G	FT	-	-
QUAKER QUINTOLUBRIC 888-68	HFDU	-	G	FT	G	-	FT	-	-

**WARNING:** Compatibility of hose and fittings with conveyed fluid is an essential factor in avoiding chemical reactions that may result in release of fluids or failure of the hose or connection. This chemical compatibility guide must not be used in conjunction with any other compatibility guides from previous or future catalogue editions, bulletins or publications. Incorrect use of these charts could result in death, personal injury or property damage.

HYDRAULIC FLUID	TYPE		WIRE SPIRAL	WIRE BRAID				TEXTILE BRAID	TPE TEXTILE BRAID
	ISO 6743-4	DIN 51524	ROCKMASTER GOLDENISO SHIELDMASTER ANACONDA FOREMASTER CRYOFLEX DIAMONDSPIR XTRAFLOW/4WS HYDROROPE HERCULES	ETERNITY/2	ROCKMASTER HARVESTER/17 SHIELDMASTER GOLDENISO COVER CRYOFLEX	FOREMASTER GOLDENISO/PILOT ROCKMASTER/1SC SYNERGY INFINITY	EQUATOR XTRAFLOW/HT	ASTRO SPIRITEX MULTITEX PUSH FIT	HYDROPLAST HYDROTWIN
QUAKER QUINTOLUBRIC 914	HFA	-	G	-	G	G	-	G	-
QUAKER QUINTOLUBRIC N 822-300	HFDU	-	G	FT	G	-	-	G	-
QUAKER QUINTOLUBRIC N 852	HEES	-	G	X	G	G	X	E	-
RAUTIO ERGO MIX	HH	-	E	G	G	-	E	-	-
REPSOL TELEX 32	HM	HLP	G	E	G	E	G	G	G
ROLOIL ESTIN S46	HFDU	-	G	FT	G	G	X	G	-
ROSNEFT GIDROTECH HVLP 46	HV	HVLP	E	G	G	G	G	G	G
SAFETY KLEEN PERFORMANCE PLUS AW 32	HM	-	G	G	FT	G	G	-	-
SHAEFFER 112 HTC	HM	HLP	G	G	G	G	E	-	-
SHAEFFER 112 NZ HTC 32	HM	HLPD	G	G	FT	G	G	FT	-
SHAEFFER 254 SUPREME ISO 32 TH 220	HM	HLP	G	FT	FT	G	G	FT	-
SHAEFFER 275 S DILEX SUPREME MEHF HYD	HV	HLPD	G	E	G	E	E	FT	-
SHELL AEROSHELL FLUID 41 (MIL 5606H)	HH	HL	E	G	G	-	FT	G	-
SHELL AEROSHELL FLUID 602 (MIL-PRF 87252C)	HEPR	-	E	E	G	G	E	G	G
SHELL ASTRON HL 46	HH	-	E	E	G	G	G	-	-
SHELL DONAX TA (TORQUE CONV. ALLISON C-3)	HM	-	-	-	G	G	G	-	-
SHELL HYDRAULIC OIL PW 46	HV	HVLP	E	G	G	E	G	G	G
SHELL IRUS FLUID DU-NA 46	HFDU	-	E	E	E	-	G	G	-
SHELL IRUS FLUID DU-NA 68	HFDU	-	E	E	E	-	G	G	-
SHELL MORLINA 220	HL	HLP	G	G	G	G	E	FT	G
SHELL MORLINA S2 BL10	HL	HLP	G	X	G	G	X	G	G
SHELL MORLINA S2 BL5	HL	HLP	G	X	G	G	X	G	G
SHELL NATURELLE HF-E15	HEES	-	E	FT	G	G	X	G	G
SHELL NATURELLE HF-E46	HEES	-	E	FT	G	G	X	E	G
SHELL TARGON AL PLUS	HH	-	E	FT	E	-	FT	G	-
SHELL TELLUS ARCTIC 32	HH	HL	G	G	G	G	G	G	E
SHELL TELLUS S 46	HM	HLP	E	G	G	G	E	G	E
SHELL TELLUS S1 M 46 (EX TELLUS H 46)	HM	-	G	G	G	G	-	-	-
SHELL TELLUS S2 M 100 (EX TELLUS 100)	HM	-	E	G	G	G	G	G	G
SHELL TELLUS S2 M 46 (EX TELLUS 46)	HM	HLP	E	G	G	G	E	G	E
SHELL TELLUS S2 M 68 (EX TELLUS 68)	HM	HLP	E	G	G	G	E	G	-
SHELL TELLUS S2 MA 46	HM	HVLP	E	G	G	E	G	G	-
SHELL TELLUS S2 MX 46	HM	HLP	G	G	G	G	G	G	G

**WARNING:** Compatibility of hose and fittings with conveyed fluid is an essential factor in avoiding chemical reactions that may result in release of fluids or failure of the hose or connection. This chemical compatibility guide must not be used in conjunction with any other compatibility guides from previous or future catalogue editions, bulletins or publications. Incorrect use of these charts could result in death, personal injury or property damage.

HYDRAULIC FLUID	TYPE		WIRE SPIRAL	WIRE BRAID				TEXTILE BRAID	TPE TEXTILE BRAID
	ISO 6743-4	DIN 51524	ROCKMASTER GOLDENISO SHIELDMASTER ANACONDA FOREMASTER CRYOFLEX DIAMONDSPIR XTRAFLOW/4WS HYDROROPE HERCULES	ETERNITY/2	ROCKMASTER HARVESTER/17 SHIELDMASTER GOLDENISO COVER CRYOFLEX	FOREMASTER GOLDENISO/PILOT ROCKMASTER/19C SYNERGY INFINITY	EQUATOR XTRAFLOW/HT	ASTRO SPIRTEX MULTITEX PUSH FIT	HYDROPLAST HYDROTWIN
SHELL TELLUS S2 V 32 (EX TELLUS T 32)	HV	HVLP	E	G	G	E	E	G	G
SHELL TELLUS S2 V 46 (EX TELLUS T 46)	HV	HVLP	E	G	G	E	E	G	G
SHELL TELLUS S2 V 68 (EX TELLUS T 68)	HV	HVLP	E	G	G	-	E	G	-
SHELL TELLUS S2 VX 46	HV	HVLP	G	G	G	G	G	G	G
SHELL TELLUS S3 M 46	HM	-	G	G	G	G	G	G	G
SHELL TELLUS S3 V 32 (EX TELLUS STX)	HV	HVLP	E	G	FT	G	E	G	G
SHELL TELLUS S3 V 46 (EX TELLUS STX)	HV	HVLP	E	G	FT	G	E	G	G
SHELL TELLUS S4 ME 46 (EX TELLUS EE 46)	HM	HLP	E	FT	-	-	-	-	-
SHELL TELLUS S4 VX 32	HV	HVLP	G	FT	-	-	-	-	-
SHELL TELLUS TX 68	HV	-	G	FT	G	E	G	G	-
SHENYANG TELI AERONAUTIC HYDRAULIC OIL 10#	HV	-	G	-	G	G	FT	-	-
SINCLAIR AW 46	HM	-	G	G	G	G	G	G	-
SINENG LHM 46	HM	-	G	G	-	-	-	-	-
SINOPEC L HM 32	HM	HLP	E	-	G	-	G	-	-
SMALLMAN CROWNPRESS 46	HH	-	G	G	G	-	E	G	E
SOLUTIA SKYDROLL 500	HFDR	-	X	X	X	-	X	X	X
STATOIL HYDRAWAY EXTREME 46	HM	HLP	E	G	G	E	E	-	-
STATOIL HYDRAWAY HVXA 15	HV	HVLP	G	-	G	G	-	G	-
STATOIL HYDROCOR CC44	HFC	-	E	G	E	E	FT	G	-
STUART ISOCORE E 68 PLUS	HPG	-	E	G	G	G	FT	E	-
SUNOCO SUNVIS 746	HM	HLP	E	G	G	G	E	FT	G
SUNOCO SUNVIS 846	HV	HVLP	E	G	G	G	G	G	G
SUNOCO SUNVIS 846 WR	HV	HLP	E	G	G	G	G	G	G
TAMOIL GREEN HYDRO SAFETY 46	HETG	-	E	E	G	-	-	E	G
TEBOIL HYDRAULIC ARCTIC	HH	-	G	G	E	G	G	E	E
TEBOIL ECO 46	HEES	-	E	E	G	G	FT	G	G
TERRESOLVE GREENSCARE 46	HETG	-	G	G	G	G	G	G	-
TEXACO BIOSTAR HYDRAULIC 32	HETG	-	E	FT	E	G	FT	E	-
TEXACO HYDRA 46	HEES	-	E	FT	G	G	FT	G	G
TEXACO RANDO HD 46	HM	HLP	E	G	G	G	G	FT	G
TEXACO RANDO HD LVZ 46	HV	HVLP	G	G	G	G	G	FT	-
TEXACO RANDO HD VZ 46	HV	HVLP	G	G	G	G	G	G	G
TEXACO RANDO HD VZ 68	HV	HVLP	G	G	G	G	G	G	-
TEXACO RANDO HD Z 46	HV	HVLP	E	G	G	G	G	G	-
TEXACO RANDO HD Z LT 32	HM	HVLP	G	G	G	G	G	G	G

**WARNING:** Compatibility of hose and fittings with conveyed fluid is an essential factor in avoiding chemical reactions that may result in release of fluids or failure of the hose or connection. This chemical compatibility guide must not be used in conjunction with any other compatibility guides from previous or future catalogue editions, bulletins or publications. Incorrect use of these charts could result in death, personal injury or property damage.

HYDRAULIC FLUID	TYPE		WIRE SPIRAL	WIRE BRAID				TEXTILE BRAID	TPE TEXTILE BRAID
	ISO 6743-4	DIN 51524	ROCKMASTER GOLDENISO SHIELDMASTER ANACONDA FOREMASTER CRYOFLEX DIAMONDSPIR XTRAFLOW/4WS HYDROROPE HERCULES	ETERNITY/2	ROCKMASTER HARVESTER/17 SHIELDMASTER GOLDENISO COVER CRYOFLEX	FOREMASTER GOLDENISO/PILOT ROCKMASTER/1SC SYNERGY INFINITY	EQUATOR XTRAFLOW/HT	ASTRO SPIRTEX MULTITEX PUSH FIT	HYDROPLAST HYDROTWIN
TEXACO RANDO WM 32	HV	HVLP	G	FT	G	G	-	G	-
TEXACO SYNSTAR HT 68	HFDU	-	G	G	E	G	FT	E	G
TOTAL AZOLLA HZS 46	HM	HLP	E	G	G	G	E	-	-
TOTAL AZOLLA ZS 46	HM	HLP	E	G	G	G	E	G	G
TOTAL BIOHYDRAN SE 46	HEES	-	G	FT	G	G	X	E	G
TOTAL EQUIVIS ZS 46	HV	HVLP	G	G	G	-	-	FT	-
TOTAL HYDRANSAFE HFDU 46	HFDU	-	E	-	G	-	-	-	-
TOTAL LHM (BRAKE FLUID)	HS	-	G	X	FT	FT	X	G	-
UKABIOL HY 46 HTG	HETG	-	G	G	E	G	G	E	G
UNIL HYDRO S46	HM	HLP	G	G	G	G	E	FT	G
UNIL OPAL HV 46	HV	HVLP	G	G	G	G	E	-	-
UNIL OPAL HVB 46	HV	HLPD	G	G	G	G	E	-	-
UNIL OPAL PO 6	HV	HVLP	E	G	G	G	G	G	G
UNIL UNIHVD ISO WG 46	HV	HLPD	E	G	G	G	E	G	G
VALVOLINE ULTRAMAX HVLP 68	HV	HVLP	G	E	G	G	E	-	-
VICKERS ECOSURE HSE 68	HEES	-	G	FT	G	G	X	FT	-
WISURA WM 3021 2,8% IN H2O	HFA	-	E	E	E	-	X	E	E
WURTH TRIATHLON HLP 46	HM	HLP	E	G	FT	G	-	-	-
YORK 777	HEES	-	G	FT	G	G	X	G	E
ZELLER+GMELIN DIVINOL DHG 46	HL	HLP	E	G	G	G	E	G	G
ZELLER+GMELIN DIVINOL HE 46	HEES	-	E	FT	G	E	-	G	-

WARNING: Compatibility of hose and fittings with conveyed fluid is an essential factor in avoiding chemical reactions that may result in release of fluids or failure of the hose or connection. This chemical compatibility guide must not be used in conjunction with any other compatibility guides from previous or future catalogue editions, bulletins or publications. Incorrect use of these charts could result in death, personal injury or property damage.

PART 2: HYDROKINETIC APPLICATIONS AND LUBRICANT OILS COMPATIBILITY CHART

(AUTOMATIC TRANSMISSION AND VARIOUS LUBRICATION SYSTEMS)

FLUID NAME	TYPE		WIRE SPIRAL	WIRE BRAID				TEXTILE BRAID	TPE TEXTILE BRAID
	ISO 6743-4	DIN 51524	ROCKMASTER GOLDENISO SHIELDMASTER ANACONDA FOREMASTER CRYOFLEX DIAMONDSPIR XTRAFLOW/4WS HYDROROPE HERCULES	ETERNITY/2	ROCKMASTER HARVESTER/17 SHIELDMASTER GOLDENISO COVER CRYOFLEX	FOREMASTER GOLDENISO/PILOT ROCKMASTER/1SC SYNERGY INFINITY	EQUATOR XTRAFLOW/HT	ASTRO SPIRTEX MULTITEX PUSH FIT	HYDROPLAST HYDROTWIN

**AUTOMATIC TRANSMISSION FLUID (ATF)**

AGIP ATF 2D GEAR (ATF DEXRON II, MERCON II SPEC)	HA	-	G	G	FT	-	G	FT	E
AVIA FLUID ATF 86	HA	-	G	G	FT	G	E	G	G
BP AUTRAN MBX (ATF DEXRON IID) - 100°C	HA	-	E	G	G	G	E	G	-
CASTROL TRANSYND RD (ATF ALLISON C4)	HA	-	G	G	G	G	E	-	E
CHEVRON DRIVETRAIN HD (ATF CATERPILLAR TO4)	HA	-	G	G	FT	G	G	FT	-
CONOCO POWERDRIVE 10W	HA	-	G	FT	-	G	G	-	-
CONOCO VERSATRANS LV ATF	HA	-	-	G	FT	G	FT	FT	-
GOLDENWEST DEXRON III M	HA	-	G	G	FT	G	E	-	-
MAG 1 FULLY SYNTHETIC ATF (ATF MERCON V, DEXRON III)	HA	-	-	G	FT	-	G	-	-
MILLERS MILLERMATIC ATF UN (ATF DEXRON II)	HA	-	-	FT	FT	-	G	-	-
MOBIL ATF 320	HA	-	G	G	FT	G	E	FT	G
SHELL ATF III D (ATF DEXRON III)	HA	-	G	FT	FT	G	E	-	-
SHELL DONAX ATF III (ATF DEXRON III)	HA	-	E	G	FT	-	E	G	-
SHELL DONAX TX (ATF DEXRON III)	HA	-	G	FT	FT	-	G	-	-
SHELL SPIRAX S2 ATF AX	HA	-	E	-	-	-	E	-	-
SHELL SPIRAX S6ATF ZM	HA	-	FT	G	X	-	FT	-	-
SHELL TELLUS S4 TXM (UTTO)	HA	-	E	G	G	G	E	G	-
TAMOIL ATF II D (ATF DEXRON IID) - 100°C	HA	-	G	G	G	-	E	-	-
TOTAL FLUID NA H3	HA	-	G	G	FT	G	E	-	-

**GEAR (MECHANICAL TRANSMISSION) FLUID**

AMSOIL PTN 320 (GEAR OIL)	C		G	G	FT	FT	G	FT	-
CASTROL OPTIGEAR SYNTHETIC X320 (GEAR OIL)	C		G	G	FT	FT	G	FT	-
CASTROL OPTIGEAR SYNTHETIC X320 WTO (GEAR OIL)	C		-	G	-	-	G	-	-
EXXON MOBIL 424 (GEAR OIL)	C		G	G	G	-	G		
FUCHS PENTOGEAR 320 WT (GESR OIL)	C		G	-	G	G	E	-	-
FUCHS PLANTO HYTRAC (UTTO GEAR OIL)	C		G	FT	G	G	FT	G	-
FUCHS RENOLIN UNISYN CLP 320 (GEAR OIL)	C		G	G	G	G	E	G	-
FUCHS RENOLIN UNISYN XT 320 (GEAR OIL)	C		G	-	G	G	E	-	-

**WARNING:** Compatibility of hose and fittings with conveyed fluid is an essential factor in avoiding chemical reactions that may result in release of fluids or failure of the hose or connection. This chemical compatibility guide must not be used in conjunction with any other compatibility guides from previous or future catalogue editions, bulletins or publications. Incorrect use of these charts could result in death, personal injury or property damage.



FLUID NAME	TYPE		WIRE SPIRAL	WIRE BRAID				TEXTILE BRAID	TPE TEXTILE BRAID
	ISO 6743-4	DIN 51524	ROCKMASTER GOLDENISO SHIELDMASTER ANACONDA FOREMASTER CRYOFLEX DIAMONDSPIR XTRAFLOW/4WS HYDROPE HERCULES	ETERNITY/2	ROCKMASTER HARVESTER/17 SHIELDMASTER GOLDENISO COVER CRYOFLEX	FOREMASTER GOLDENISO/PILOT ROCKMASTER/1SC SYNERGY INFINITY	EQUATOR XTRAFLOW/HT	ASTRO SPIRITEX MULTITEX PUSH FIT	HYDROPLAST HYDROTWIN
FUCHS RENOLIT CX FO 20 (GEAR GREASE)	C		E	E	E	E	G	G	G
FUCHS RENOLIT CX SPS (GEAR GREASE)	C		E	E	E	E	G	G	G
LIEBHERR GEAR BASIC 90 LS (GEARBOX OIL)	C		G	G	G	-	-	G	-
MAV SINT PLUS 2005 ISO46 (GEAR OIL)	C		G	G	FT	G	FT	G	-
MOBIL MOBILGEAR SHC XMP 320 (GEAR OIL)	C		E	G	G	G	E	G	-
MOBIL SHC GEAR 320 WT (GEAR OIL)	C		E	G	G	G	E	G	-
MOBIL SHC PM 320 (GEAR OIL)	C		G	G	FT	-	E	-	-
PENZOIL LONG LIFE GEARPLUS 75W 90	C		E	G	G	E	G	G	-
SHELL DONAX TD (UTTO GEAR OIL)	C		E	G	G	G	E	-	-
SHELL OMALA HD 150 (GEAR OIL)	C		G	G	FT	-	FT	G	G
SHELL OMALA S5 WIND 320 (GEAR OIL)	C		G	G	FT	G	G	G	-
SHELL SPIRAX ASX (GEAR OIL SAE 80W140)	C		G	FT	FT	FT	FT	G	
SHELL TEGULA V32 (GEAR OIL)	C		E	G	G	-	E	G	E
SINOPEC GREATWALL WT 320 (GEAR OIL)	C		G	G	G	G	E	G	G
TEXACO TEXTRAN TDH PREMIUM (UTTO GEAR OIL)	C		G	G	G	G	E	G	
VALTRA TRANSMISSION OIL XT 60 (GEARBOX)	C		G	G	FT	-	E	FT	-

COMPRESSOR OILS

ANDEROL 497 (DI-ESTER BASED COMPRESSOR OIL)	D		G	FT	G	-	FT	G	-
ATLAS COPCO HD ROTO FLUID PLUS	D		-	-	-	-	G	-	-
ATLAS COPCO PAROIL S BULK (SYNT. ESTER POLYOLEFINE BLEND COMPR.)	D		G	G	FT	-	FT	FT	
ATLAS COPCO ROTO EXTREME DUTY FLUID	D		-	-	-	-	FT	-	-
ATLAS COPCO ROTO FOODGRADE FLUID (SYNT BLEND COMPR. OIL)	D		-	-	-	-	G	-	-
ATLAS COPCO ROTO H (MINERAL BASED COMPRESSOR OIL)	D		G	G	FT	-	G	G	E
ATLAS COPCO ROTO INJECT FLUID PLUS (MINERAL BASED COMPR. OIL)	D		G	G	FT	-	G	G	E
ATLAS COPCO ROTO INJECT FLUID (MINERAL BASED COMPR. OIL)	D		E	G	G	-	G	G	E
ATLAS COPCO ROTO XTEND DUTY (PAO COMPR. OIL)	D		-	-	-	-	G	-	-
ATLAS COPCO ROTO Z	D		-	-	-	-	G	-	-

WARNING: Compatibility of hose and fittings with conveyed fluid is an essential factor in avoiding chemical reactions that may result in release of fluids or failure of the hose or connection. This chemical compatibility guide must not be used in conjunction with any other compatibility guides from previous or future catalogue editions, bulletins or publications. Incorrect use of these charts could result in death, personal injury or property damage.

FLUID NAME	TYPE		WIRE SPIRAL	WIRE BRAID				TEXTILE BRAID	TPE TEXTILE BRAID
	ISO 6743-4	DIN 51524	ROCKMASTER GOLDENISO SHIELDMASTER ANACONDA FOREMASTER CRYOFLEX DIAMONDSPIR XTRAFLOW/4WS HYDROROPE HERCULES	ETERNITY/2	ROCKMASTER HARVESTER/17 SHIELDMASTER GOLDENISO COVER CRYOFLEX	FOREMASTER GOLDENISO/PILOT ROCKMASTER/1SC SYNERGY INFINITY	EQUATOR XTRAFLOW/ HT	ASTRO SPIRTEX MULTITEX PUSH FIT	HYDROPLAST HYDROTWIN
BARHAT PETROLEUM AIRLUBE XD	D		-	-	-	-	G	-	-
CASTROL ICEMATIC SW 100 (POE BASED COMPRESSOR OIL)	D		G	G	G	-	-	G	E
CHEVRON MACHINE OIL ISO 32 (COMPRESSOR OIL)	D		G	G	G	-	G	G	G
FUCHS DEA TRITON SE 55 (POE BASED)	D		G	G	G	G	-	G	E
FUCHS RENISO C85 E	D		G	FT	G	G	-	G	-
FUCHS RENISO PAG 1234	D		G	G	G	G	-	G	G
INGERSOLL RAND SSR ULTRA PLUS COOLANT (POE BASED COMPR. OIL)	D		G	G	G	-	E	G	G
ISAFLEX KOMPRESSOIL SE	D		-	FT	G	G	FT	-	-
KLUBER SUMMIT HYSIN F 46	D		G	G	FT	G	-	-	-
KLUBER SUMMIT HYSYN FG 46 (SYNT HYDROCARBON COMP. OIL)	D		G	G	FT	G	G	FT	-
LUBRIZOL EMKARATE RL 100S	D		G	G	-	-	-	FT	G
MOBIL ARCTIC EAL 32 (POE BASED A/C COMP. OIL)	D		-	FT	G	-	X	G	G
MOBIL GLYCOL 30 (PAG BASED COMP.OIL)	D		E	E	E	E	E	E	G
MOBIL RARUS SHC 1026 (COMPRESSOR OIL)	D		E	G	G	-	E	G	-
PAG SP 10 (COMPRESSOR OIL)	D		G	G	G	-	-	FT	E
SHELL CORENA D (COMPRESSOR OIL)	D		G	G	FT	-	E	FT	G
SULLAIR AWF	D		-	-	-	-	G	-	-
TOTAL DACNIS SH 46 (PAO BASED COMP. OIL)	D		-	G	G	G	E	G	-
TOTAL DACNIS VS 46 (MINERAL BASED COMP. OIL)	D		G	G	G	G	E	FT	-
VALVOLINE VALCOMP SYNTH 68 COMP. OIL	D		-	-	-	-	G	-	-

ENGINE OILS

AGIP SINT 2000 (ENGINE OIL 10W40)	E		G	G	G	-	G	E	G
AGIP TECSINT SL5W40 (ENGINE OIL 5W40)	E		E	G	FT	-	G	-	-
ARAL TURBORAL (ENGINE OIL 15W40)	E		E	G	-	-	-	-	-
BP VANELLUS C 5 (ENGINE OIL 15W40)	E		E	G	G	G	G	-	-
CHEVRON DELO 400LE (ENGINE OIL 15W40)	E		G	G	FT	G	G	G	-
CHEVRON RPM 30 (ENGINE OIL)	E		G	G	G	G	E	G	-
FUCHS PLANTOHYDRAMOT SL 5W40 (STOU ENGINE OIL)	E		G	G	FT	G	G	G	-
FUCHS TITAN GTI PRO C 2 (ENGINE OIL 5W30)	E		G	G	G	-	FT	G	-

**WARNING:** Compatibility of hose and fittings with conveyed fluid is an essential factor in avoiding chemical reactions that may result in release of fluids or failure of the hose or connection. This chemical compatibility guide must not be used in conjunction with any other compatibility guides from previous or future catalogue editions, bulletins or publications. Incorrect use of these charts could result in death, personal injury or property damage.

FLUID NAME	TYPE		WIRE SPIRAL	WIRE BRAID				TEXTILE BRAID	TPE TEXTILE BRAID
	ISO 6743-4	DIN 51524	ROCKMASTER GOLDENISO SHIELDMASTER ANACONDA FOREMASTER CRYOFLEX DIAMONDSPIR XTRAFLOW/4WS HYDROPE HERCULES	ETERNITY/2	ROCKMASTER HARVESTER/17 SHIELDMASTER GOLDENISO COVER CRYOFLEX	FOREMASTER GOLDENISO/PILOT ROCKMASTER/1SC SYNERGY INFINITY	EQUATOR XTRAFLOW/ HT	ASTRO SPIRITEX MULTITEX PUSH FIT	HYDROPLAST HYDROTWIN
IGOL MARINE 15W-40 (ENGINE OIL )	E		G	G	G	-	-	-	-
JCB ENGINE OIL EP (ENGINE OIL 15W40)	E		E	G	G	-	G	G	G
MOBIL DELVAC MX (ENGINE OIL 15W40)	E		E	G	-	-	-	-	-
MOBIL DELVAC 1310 (ENGINE OIL 10W20)	E		E	G	G	-	G	E	G
Q8 T1000 (ENGINE OIL 15W40 - STUO)	E		G	G	G	G	G	G	G
Q8 T720 (ENGINE OIL 15W40)	E		E	G	G	-	E	G	-
Q8 T760 (ENGINE OIL 15W40)	E		G	G	FT	G	G	G	G
SHELL HELIX ULTRA (ENGINE OIL 5W40)	E		G	G	G	-	E	G	-
SHELL RIMULA R3 (ENGINE OIL 10W)	E		E	G	G	-	E	G	E
SHELL RIMULA R3 MV (ENGINE OIL)	E		E	E	G	G	-	G	G
SHELL RIMULA R4 X (ENGINE OIL 15W40)	E		E	G	-	-	-	-	-
SHELL RIMULA X30 (ENGINE OIL 10W)	E		E	G	G	G	E	G	E
SHELL ROTELLA TMG (ENGINE OIL 15W40)	E		G	G	G	G	E	G	
SHELL V OIL 1404	E		G	G	G	-	G	G	G
<b>TURBINE OILS</b>									
MOBIL JET OIL II	T		E	FT	G	E	FT	E	-
NYCO TURBONICOIL TN 13 B	T		G	X	X	FT	X	E	-
<b>HEAT TRANSFER FLUIDS</b>									
CHEVRON HAVOLINE XLC (FLUID COOLER)	Q		E	G	G	-	X	G	-
MOBIL THERM 605	Q		G	G	G	-	E	G	-
NESTE FLUID COOLER BIO	Q		E	G	G	G	-	G	-
NESTE SUPER FLUID COOLER XLC	Q		E	G	G	-	-	G	-
PETROCANADA CALFLO (HEAT TRANSFER FLUID)	Q		G	G	G	E	G	G	-
PETRONAS PARAFLO HT (OAT) AT 100°C	Q		E	G	G	-	X	G	-
WATER GLYCOL EMULSION (50%) AT 100°C	Q		E	G	G	-	X	G	E
<b>METAL WORKING</b>									
BUDEMEIM PHOSPHATHERM 948	M		E	E	E	-	X	E	-
CASTROL VARIOCUT G613 HC (CUTTING OIL)	M		-	FT	-	FT	X	-	-

**WARNING:** Compatibility of hose and fittings with conveyed fluid is an essential factor in avoiding chemical reactions that may result in release of fluids or failure of the hose or connection. This chemical compatibility guide must not be used in conjunction with any other compatibility guides from previous or future catalogue editions, bulletins or publications. Incorrect use of these charts could result in death, personal injury or property damage.

PART 3: BEHAVIOUR TO CHEMICALS FOR NON-HYDRAULIC APPLICATIONS

(GUIDELINES FROM LITERATURE)

FLUID	NITRILE	CHLOROPRENE	CHLOROSULPHONATED POLYETHYLENE	CHLORINATED POLYETHYLENE	POLYESTER
ACETALDHEIDE	X	FT	X	FT	G
ACETIC ACID, 10%	X	FT	G	G	G
ACETIC ACID GLACIAL	X	X	FT	G	FT
ACETONE	FT	FT	X	G	G
AIR (60°C)	G	G	E	E	E
AIR (100°C)	FT	G	E	E	G
AIR (150°C)	X	X	G	G	X
AMMONIA, GASEOUS	FT	G	-	-	X
AMMONIA, LIQUID COLD	E	E	G	-	X
AMMONIA, LIQUID 70°C	X	FT	FT	-	X
AMMONIUM HYDROXIDE, 10%	G	G	E	E	-
AMMONIUM HYDROXIDE, CONC	FT	FT	FT	FT	-
AMMONIUM NITRATE (AQUEOUS SOLUTIONS)	G	G	G	G	G
AMMONIUM PHOSPHATE, MON-DI-TRI BASIC (AQ. SOL)	E	E	E	E	FT
AMMONIUM SULPHATE (AQUEOUS SOLUTION)	E	E	E	E	FT
ANILINE	X	FT	X	X	X
AQUA REGIA	FT	FT	X	FT	-
ASTM OIL N°1, 100°C	E	E	G	G	E
ASTM OIL N°2, 100°C	E	G	FT	FT	E
ASTM OIL N°3, 100°C	E	FT	FT	FT	E
BENZENE	X	X	X	FT	FT
BORIC ACID 10% 100°C	G	G	G	X	G
BRAKE FLUID (SAE J 1703D)	X	-	X	G	-
BRINE	E	FT	FT	G	G
BUTANOL	E	G	G	G	E
CALCIUM BICARBONATE	E	E	E	E	-
CALCIUM HYDROXIDE (AQUEOUS SUSPENSIONS)	E	E	G	G	-
CARBONIC ANHYDRIDE	G	E	G	G	E
CHLORINE	X	X	X	X	X
CHLOROFORM	FT	FT	X	X	X
CITRIC ACID, 33%	G	G	G	-	E
CRUDE OIL	E	X	X	X	G
DETERGENT WATER SOLUTION	G	G	FT	G	G
DIBENZYL ETHER	X	X	X	X	-
DIETHYL PHTALATE (DEPH)	FT	X	X	X	E
EPICHLORHYDRINE	X	X	FT	X	X
ETHYL ACETATE	FT	X	FT	FT	FT
ETHYL ALCOHOL	E	E	E	E	E

APPENDIX 642

**WARNING:** Compatibility of hose and fittings with conveyed fluid is an essential factor in avoiding chemical reactions that may result in release of fluids or failure of the hose or connection. This chemical compatibility guide must not be used in conjunction with any other compatibility guides from previous or future catalogue editions, bulletins or publications. Incorrect use of these charts could result in death, personal injury or property damage.

FLUID	NITRILE	CHLOROPRENE	CHLOROSULPHONATED POLYETHYLENE	CHLORINATED POLYETHYLENE	POLYESTER
ETHYL ETHER	G	FT	-	-	-
ETHYLENE	E	G	-	-	G
ETHYLENE GLYCOLE	E	E	G	G	E
ETHYLENE GLYCOLE (100°C)	E	G	G	G	G
FORMALDHEYDE	FT	G	FT	G	G
FORMIC ACID 23°C (SATURATED SOLUTION)	G	G	G	X	G
FORMIC ACID 75°C (SATURATED SOLUTION)	FT	G	FT	X	FT
GLYCERINE	E	E	E	E	E
HEPTANE	G	FT	X	FT	E
HYDRAULIC OILS (SEE DETAILED TABLE)	*	*	*	*	*
HYDROCHLORIC ACID, 10%	G	G	G	X	G
HYDROCHLORIC ACID, 37%	FT	FT	FT	X	X
HYDROCHLORIC ACID, 37% 70°C	X	X	X	X	X
HYDROCYANIC ACID 20%	FT	FT	-	-	-
HYDROGEN SULPHIDE	FT	G	FT	X	E
ISOBUTYL ALCOHOL	G	G	G	G	E
ISOPROPYL ALCOHOL	G	E	E	E	E
ISO-OCTANE	G	FT	X	FT	E
KEROSENE (AROMATICS 40%MAX, 70°C)	G	FT	X	FT	-
LEAD FREE PETROL	G	FT	X	FT	E
MAGNESIUM HYDROXIDE (AQUEOUS SOLUTIONS)	G	E	E	E	-
MERCURY	E	E	E	E	E
METHANOL	G	E	E	E	G
METHYL METHACRYLATE	X	X	X	X	-
METHYLETHYLKETONE (MEK)	X	FT	X	FT	E
NITRIC ACID, CONCENTRATED 65%	X	X	X	X	X
NITRIC ACID, DILUTED 10% 50°C	FT	X	X	FT	X
NITRIC ACID FUMING	X	X	X	X	X
NITROGEN	E	E	E	E	E
OLEIC ACID	G	FT	FT	FT	E
OLEUM	X	X	X	X	X
OXALIC ACID 25% 80°C	G	E	G	X	-
OXYGEN (80°C)	FT	G	FT	G	E
PARAFFIN	E	E	FT	E	E
PENTANE	G	FT	X	FT	E
PETROL	E	FT	X	FT	E
PETROLEUM, 70°C	E	G	X	FT	E
PHENOL	X	X	X	X	FT
PHOSPHORIC ACID 20%	G	E	E	X	-
PHOSPHORIC ACID 60% 50°C	FT	G	FT	X	-

**WARNING:** Compatibility of hose and fittings with conveyed fluid is an essential factor in avoiding chemical reactions that may result in release of fluids or failure of the hose or connection. This chemical compatibility guide must not be used in conjunction with any other compatibility guides from previous or future catalogue editions, bulletins or publications. Incorrect use of these charts could result in death, personal injury or property damage.

FLUID	NITRILE	CHLOROPRENE	CHLOROSULPHONATED POLYETHYLENE	CHLORINATED POLYETHYLENE	POLYESTER
PHOSPHORIC ACID 85%	FT	G	FT	X	-
PHOSPHOROUS TRI-CHLORIDE	X	X	X	X	-
PICRIC ACID 10% 100°C	FT	FT	G	G	-
POTASSIUM CHLORIDE (AQUEOUS SOLUTION)	E	E	E	E	-
POTASSIUM HYDROXIDE 70°C (MEDIUM HIGH CONC.)	G	G	-	-	E
POTASSIUM SULPHATE (AQUEOUS SOLUTION)	E	E	E	E	-
SEA WATER	E	G	FT	G	E
SOAPS	E	G	G	G	E
SODA CAUSTIC	FT	G	G	FT	G
SODIUM BICARBONATE	E	E	E	E	G
SODIUM CHLORIDE (AQUEOUS SOLUTION)	E	E	G	G	E
SODIUM HYDROXIDE	FT	G	G	FT	E
SODIUM HYDROXIDE 70°C (MEDIUM HIGH CONC.)	FT	G	G	FT	F
SODIUM HYPOCHLORITE (AQUEOUS SOLUTIONS)	FT	G	FT	X	E
SODIUM SILICATE (AQUEOUS SOLUTIONS)	E	E	E	E	-
SODIUM SULPHATE (AQUEOUS SOLUTION)	E	E	E	E	-
SODIUM SULPHIDE	E	E	E	E	-
STEARIC ACID	E	E	FT	E	E
SULPHUR	X	X	G	G	-
SULPHUR DIOXIDE	X	X	X	X	-
SULPHURIC ACID (HOT CONCENTRATED 96°C)	X	X	X	X	X
SULPHURIC ACID (DILUTED 20%)	X	X	FT	FT	E
SULPHURIC ANHYDRIDE	X	FT	FT	FT	-
SULPHUROUS ACID	X	X	FT	FT	X
TANNIC ACID	G	G	G	X	E
TANNIN	E	E	E	E	E
TARTARIC ACID 20%	E	G	G	X	-
TETRAETHYL LEAD	G	FT	X	-	-
TOLUENE	X	X	X	X	E
TURPENTINE	G	X	X	X	-
UREA	E	E	G	G	-
VINYL ACETATE	FT	FT	FT	G	-
VINYL CHLORIDE	X	X	X	X	-
WATER	E	G	X	G	E
XYLENE	FT	X	X	X	G
ZINC CHLORIDE (AQUEOUS SOLUTIONS)	E	E	G	X	E
ZINC SULPHATE (AQUEOUS SOLUTIONS)	E	E	G	X	-

**WARNING:** Compatibility of hose and fittings with conveyed fluid is an essential factor in avoiding chemical reactions that may result in release of fluids or failure of the hose or connection. This chemical compatibility guide must not be used in conjunction with any other compatibility guides from previous or future catalogue editions, bulletins or publications. Incorrect use of these charts could result in death, personal injury or property damage.

## DIRECT TO PORT CONCEPTS

The male threadless termination can be connected directly to the port, by means of pre-installed cartridge, with a simple axial pushing action of the fitting into the port.

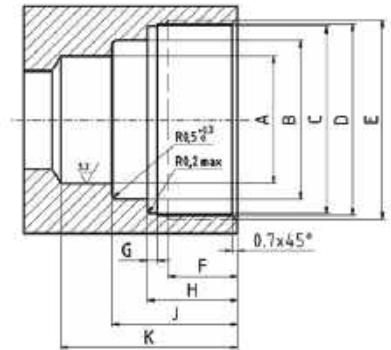

## FEMALE PORT DESIGN

SIZE	DIMENSIONS (MM)					RECOMMENDED TORQUE
	A	B	C	D	E	
-04	10.03 + 0.08	12.75 + 0.1	16.55 + 0.07	17.0 + 0.1	M18 X 1	23 - 35 NM
-06	13.03 + 0.08	16.9 + 0.2	20.55 + 0.07	21.0 + 0.1	M22 X 1	30 - 40 NM
-08	16.03 + 0.08	19.9 + 0.2	23.55 + 0.07	24.0 + 0.1	M25 X 1	40 - 50 NM
-12	23.03 + 0.08	27.9 + 0.2	31.05 + 0.07	31.5 + 0.1	M33 X 1.5	70 - 80 NM

SIZE	DIMENSIONS (MM)					RECOMMENDED TORQUE
	F	G	H	I	J	
-04	8.5 + 1	1.1 - 0.1	10.35 + 0.1	14.15 + 0.2	19.56 + 0.15	23 - 35 NM
-06	8.7 + 1	1.15 - 0.1	11.1 + 0.1	15.5 + 0.2	21.95 + 0.15	30 - 40 NM
-08	8.7 + 1	1.25 - 0.1	11.3 + 0.1	15.7 + 0.2	22.15 + 0.15	40 - 50 NM
-12	11.5 + 1	1.7 - 0.1	16.5 + 0.1	21.4 + 0.2	31.35 + 0.15	70 - 80 NM

**ASSEMBLING PROCEDURE**

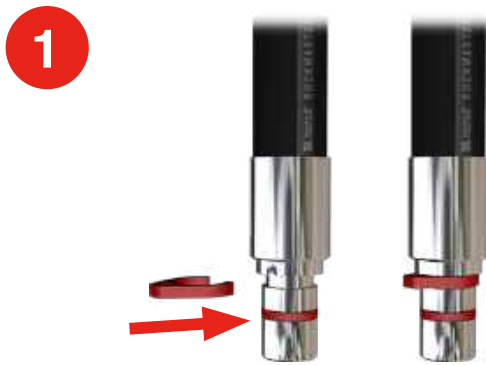

Fit the safety clip into the dedicated groove on the male fitting.

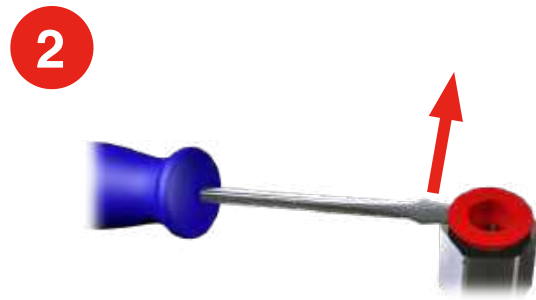

Use a flat-headed screwdriver, or similar tool, to remove the protective cap on the cartridge.



Connect the fitting by pushing it into the cartridge. The fitting is correctly locked and connected when the safety clip touches the cartridge.

**ASSEMBLING INSTRUCTIONS**

When inserting the male fitting into the cartridge, the axial force required to ensure correct and secure assembly will vary throughout the insertion process (see graph opposite). In particular there will be a two points where the amount of force required will be noticeably higher.

The first peak (A), occurs when the internal collars of the cartridge are opening; For a -08 fitting this would typically be around 20 kgf.

The second peak (B), occurs when the plastic retaining ring is being inserted into the cartridge. This peak is significantly lower than the first.

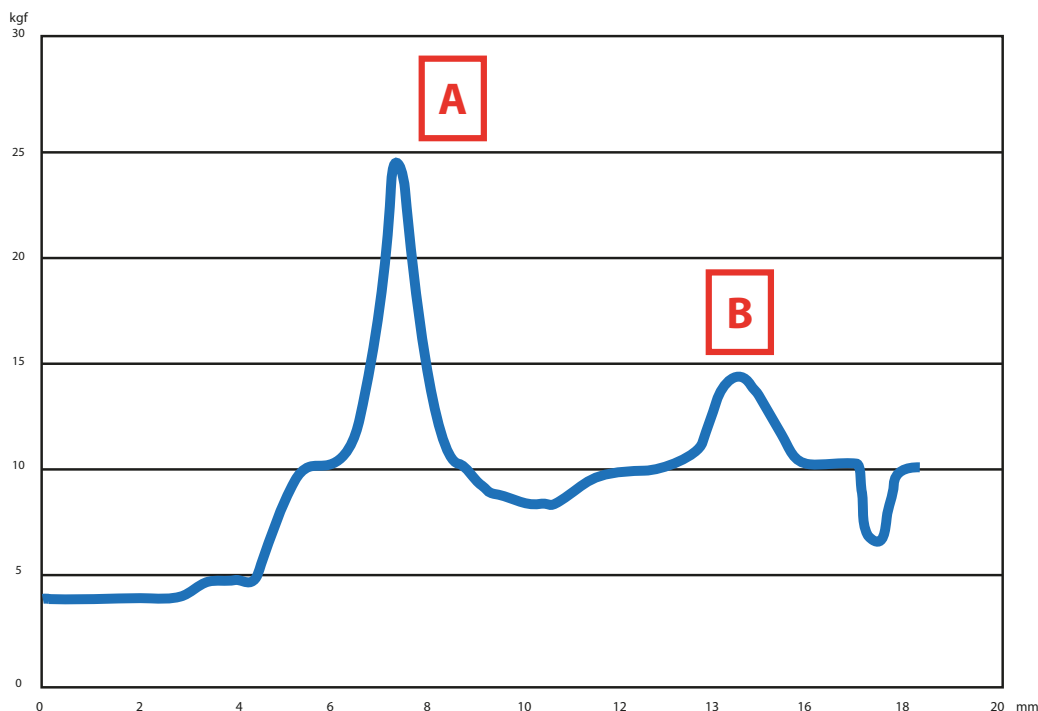



## DIS-ASSEMBLING PROCEDURE



Before disconnection, ensure the system is not under pressure

1



Use a flat-headed screwdriver, or similar tool, to remove the safety clip.

2

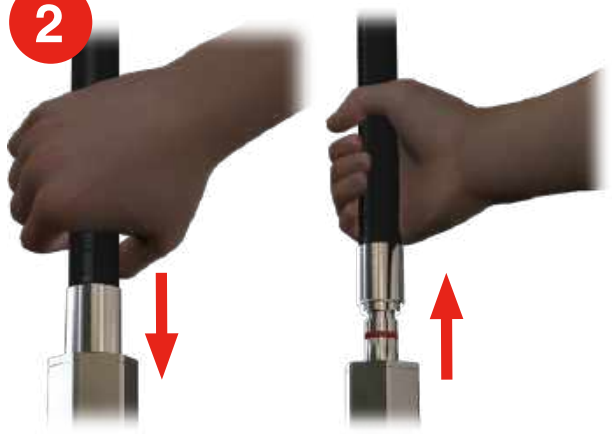

Push the fitting in until the collar touches the cartridge, then pull out to complete the disconnection process. Use a flat-headed screwdriver, or similar tool, to remove the protective cap on the cartridge.

## DIS-ASSEMBLING INSTRUCTIONS

The maximum axial force required to separate the components (after the initial “push”) is approximately 10 kgf for a -08 fitting - see graph opposite.

The peak (C) represents the force required to open the internal retaining ring to allow the withdrawal of the male fitting.

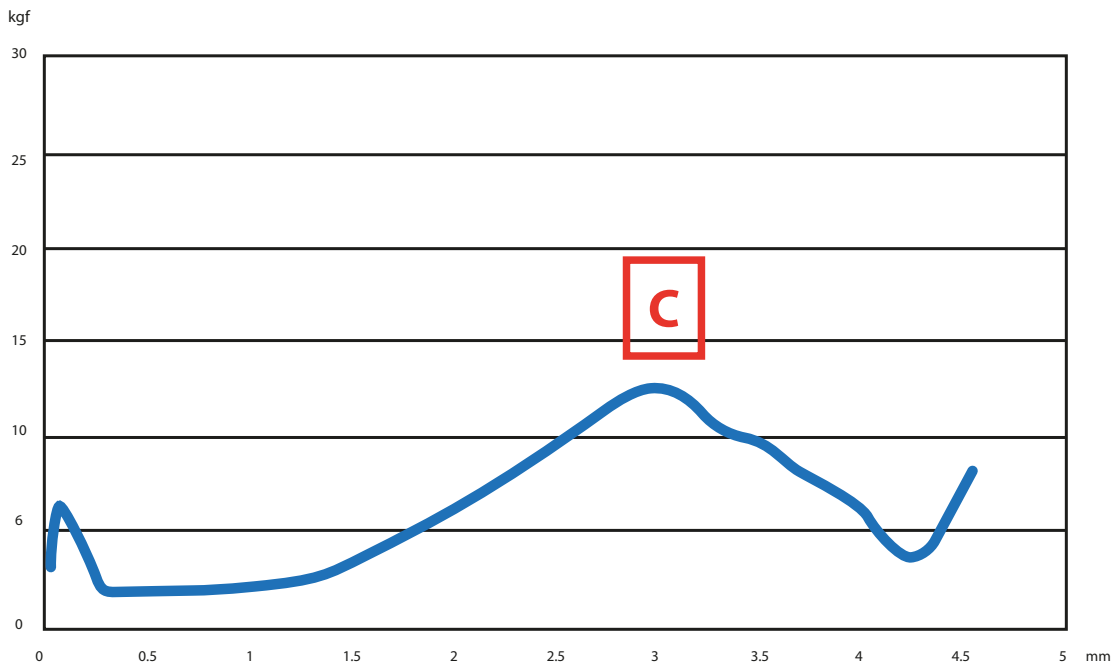

O-RING AND BACK-UP RING SEAL REPLACEMENT ON FEMALE COUPLINGS

1

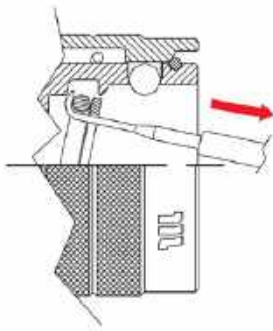

Remove the damaged O-ring and back-up ring.



Do not use sharpened tools. Take care not to damage the components.

2

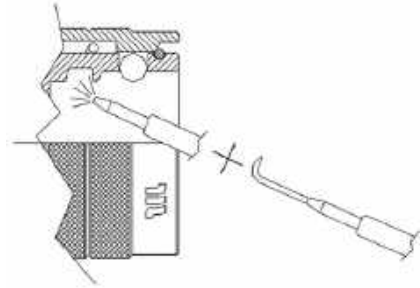

Clean the seal area.



Remove all residual parts of damaged O-ring and back-up ring.

3

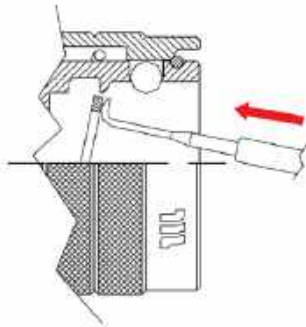

Insert the new back-up ring.



Take care not to deform or scratch the back-up ring. Ensure the back-up ring is correctly located in its seat.

4

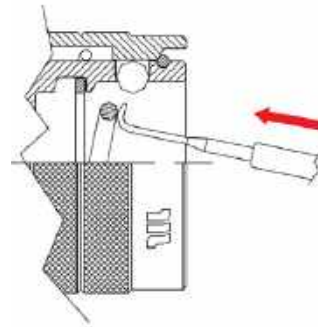

Insert the new O-ring.



Lubricate the O-ring before inserting. Take care not to scratch the O-ring. Ensure the O-ring is correctly located in its seat.

5

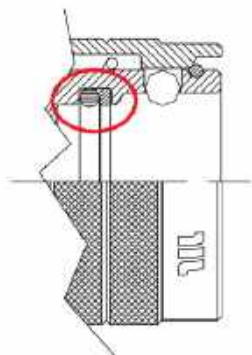

The replacement process is now complete.



Lubricate the seal system.

**POLYURETHANE SEAL REPLACEMENT ON MALE FLAT-FACE COUPLINGS**

**1**

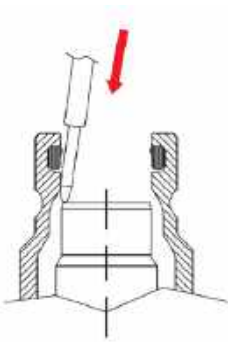

Use a suitable tool to pull back the valve and hold it in place.



**Do not use sharpened tools. Take care not to damage the components.**

**2**

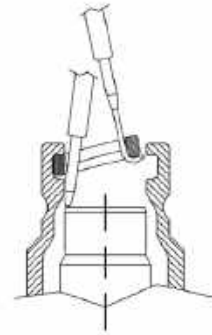

Remove the damaged seal.



**Take care not to damage the components.**

**3**

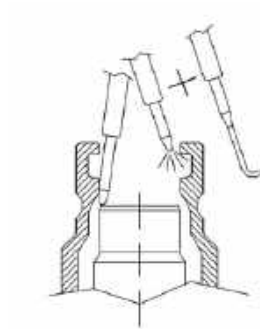

Clean the seal area.



**Remove all residual parts of polyurethane seal.**

**4**

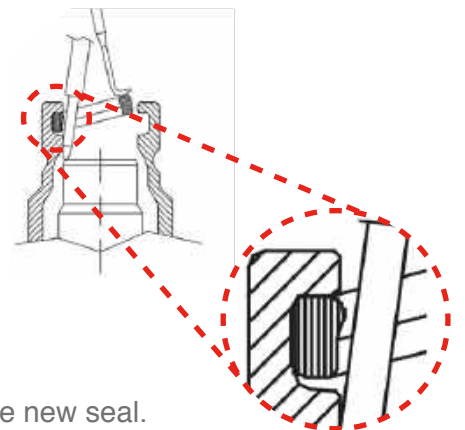

Insert the new seal.



**Ensure the seal is correctly oriented. Lubricate the seal before inserting. Take care not to scratch the seal. Ensure the seal is correctly located in its seat.**

**5**

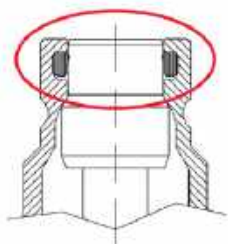

Release the valve to complete the replacement process.



**Lubricate the seal system.**

HOSE

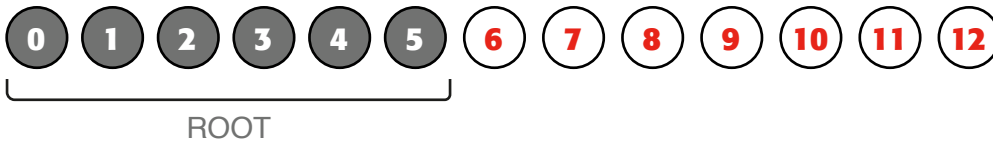

"H" letter always means "Hoses"



**Family**

"Five digit number" that defines a specific hose family - see "Hose Family Table".

Digit "1"	Hose Type	Digits "1-2"	Hose Type
0	Hydraulic rubber hose	10	Hydraulic rubber hose
2	Thermoplastic hose	16	Textile braided - Traded
3	Traded hose		
7	Oil & marine hose		
8	Industrial hose		
9	PTFE hose		



Progressive **letter** (A, B, ... ) is used to identify an updated structure

In case a **number** is used, it must be read together with digits "7" and "8" to identify the hose's diameter in mm



**Diameter** in millimetres

In case digit "6" is a number, the hose diameter in millimetres should be read including it.

HOSE (CONTINUED)

**DIGIT "9"** 0 1 2 3 4 5 6 7 8 9 10 11 12

Value	Package	Marking Technology
O	Box	Ink transfer
B	Reel	Ink transfer
P	Plastic reel	Ink transfer
R	Roll	Ink transfer
W	Wooden reel	Ink transfer
E	Defined in digit "10"	Embossed / embedded
I	Defined in digit "10"	Inkjet
M	Defined in digit "10"	Mylar

**DIGIT "10"** 0 1 2 3 4 5 6 7 8 9 10 11 12

Value	Package	Special
L	Box ( $\leq$ DN51); Wooden reel ( $>$ DN51)	Branding with License Number
O	Box	-
B	Reel	-
P	Plastic reel	-
R	Roll	-
W	Wooden reel	-
A	Box	100 ft (spiralled) / 50 ft (GoldenBlast)
Q	Box	40 m (GoldenBlast)
S, V, Z, Y	Box	Special length
C	-	Branding without "Made in..." declaration

**DIGIT "11"** 0 1 2 3 4 5 6 7 8 9 10 11 12

Value	Special
S, V, Z, Y	Special length
C	Branding without "Made in..." declaration
9	Manuli standard branding
O-8	Private brand
4	Soft Seal Sleeve

HOSE (CONTINUED)

**DIGIT "12"**    0   1   2   3   4   5   6   7   8   9   10   11   12

Value	Special
9	Manuli standard branding
0-8	Private brand

Notes for digits "9-10-11-12"

If the above convention is NOT followed then the branding is considered "Private". Exceptions related to "Manuli Brand" hoses are: x900; xx90; x556; x833; x962; xx97; xx95

HOSE FAMILIES

FIRST 6 DIGITS	PROD. TECH.	PROD. TECH. DESCRIPTIONS	FAMILY	FAMILY DESCRIPTION
H01006	1	WIRE BRAIDED	6	TRACTOR/1SN
H01007	1	WIRE BRAIDED	7	ROCKMASTER/1SN
H01013	1	WIRE BRAIDED	13	TRACTOR/1SC
H01015	1	WIRE BRAIDED	15	PILOT
H01025	1	WIRE BRAIDED	25	TRACTOR/2SC
H01027	1	WIRE BRAIDED	27	TRACTOR/2SN
H01030	1	WIRE BRAIDED	30	ROCKMASTER/2SC
H01031	1	"WIRE BRAIDED; WIRE SPIRALLED"	31	SHIELDMASTER/4000
H01032	1	"WIRE BRAIDED; WIRE SPIRALLED"	32	SHIELDMASTER/5000
H01033	1	WIRE BRAIDED	33	CPH/2SC
H01034	1	WIRE BRAIDED	34	JACKMASTER
H01035	1	WIRE BRAIDED	35	ROCKMASTER/2ST
H01038	1	WIRE BRAIDED	38	ROCKMASTER/2SN
H01039	1	WIRE BRAIDED	39	NOZONE/2K
H01056	1	WIRE BRAIDED	56	HARVESTER/17
H01058	1	WIRE BRAIDED	58	EQUATOR/1 BLACK
H01059	1	WIRE BRAIDED	59	EQUATOR/1 BLUE
H01060	1	WIRE BRAIDED	60	EQUATOR/2 BLACK
H01061	1	WIRE BRAIDED	61	EQUATOR/2 BLUE
H01084	1	WIRE BRAIDED	84	LYTE-FLEX
H01101	1	WIRE BRAIDED	101	ROCKMASTER/2 PLUS
H01102	1	WIRE BRAIDED	102	ETERNITY/2
H01104	1	"WIRE BRAIDED; WIRE SPIRALLED"	104	SHIELDMASTER/5000 MINE
H01105	1	WIRE BRAIDED	105	SHIELDMASTER/2SC MINE
H01106	1	WIRE BRAIDED	106	SHIELDMASTER/2000

## HOSE FAMILIES (CONTINUED)

FIRST 6 DIGITS	PROD. TECH.	PROD. TECH. DESCRIPTIONS	FAMILY	FAMILY DESCRIPTION
H01108	1	WIRE BRAIDED	108	ROCKMASTER/1SC
H01110	1	WIRE BRAIDED	110	REFRISTAR
H01112	1	WIRE BRAIDED	112	TWINPOWER/PLUS
H01113	1	WIRE BRAIDED	113	FLUICONNECTO 2SN
H01119	1	WIRE BRAIDED	119	TWINPOWER 4000
H01120	1	WIRE BRAIDED	120	TWINPOWER 5000
H01122	1	WIRE BRAIDED	122	SHIELDMASTER/2 PLUS MINE
H01124	1	WIRE BRAIDED	124	FIREND
H01125	1	WIRE BRAIDED	125	GOLDENISO/21 ANTIWEAR
H01126	1	WIRE BRAIDED	126	GOLDENISO/28 ANTIWEAR
H01127	1	WIRE BRAIDED	127	TREX
H01128	1	WIRE BRAIDED	128	XTRAFLOW/ HT
H01129	1	WIRE BRAIDED	129	XTRAFLOW/2WB
H01133	1	WIRE BRAIDED	133	ULTRASTAR
H01134	1	WIRE BRAIDED	134	GOLDENISO/35 LONGLIFE
H01135	1	WIRE BRAIDED	135	LUBEMASTER
H01154	1	WIRE BRAIDED	154	SHIELDMASTER/21
H01155	1	"WIRE BRAIDED; WIRE SPIRALLED"	155	SHIELDMASTER/28
H01157	1	WIRE BRAIDED	157	FOREMASTER/28
H01156	1	WIRE BRAIDED	156	FOREMASTER/21
H01158	1	WIRE BRAIDED	158	CRYOFLEX/21
H01159	1	WIRE BRAIDED	159	CRYOFLEX/35
H01A32	1	"WIRE BRAIDED; WIRE SPIRALLED "	A32	SHIELDMASTER/6000
H01A78	1	WIRE BRAIDED	A78	SUPERJET/PLUS
H01A79	1	WIRE BRAIDED	A79	SUPERJET/PLUS BLUE
H01A94	1	WIRE BRAIDED	A94	PROJET
H01A95	1	WIRE BRAIDED	A95	PROJET BLUE
H02001	2	SMOOTH HOSES	1	SUPERJET
H02002	2	SMOOTH HOSES	2	SUPERJET BLUE
H02003	2	SMOOTH HOSES	3	K-JET
H02004	2	SMOOTH HOSES	4	TRACTOR/1SN
H02008	2	SMOOTH HOSES	8	K-JET BLUE
H02011	2	SMOOTH HOSES	11	GOLDENISO/14
H05002	5	WIRE BRAIDED (R5 HOSE TYPE)	2	COVER
H09002	9	TEXTILE	2	REFRIMASTER
H09045	9	TEXTILE	45	ASTRO/2
H09046	9	TEXTILE	46	ASTRO/3
H09066	9	TEXTILE	66	PUSHFIT
H09067	9	TEXTILE	67	MULTITEX

## HOSE FAMILIES (CONTINUED)

FIRST 6 DIGITS	PROD. TECH.	PROD. TECH. DESCRIPTIONS	FAMILY	FAMILY DESCRIPTION
H09069	9	TEXTILE	69	MASTERTEX
H09071	9	TEXTILE	71	REFRIMASTER PLUS
H09073	9	TEXTILE	73	MULTITEX
H10008	10	WIRE SPIRALLED	8	ROCKMASTER/4SP
H10018	10	WIRE SPIRALLED	18	DIAMONDSPIR
H10031	10	WIRE SPIRALLED	31	ROCKMASTER/12
H10035	10	WIRE SPIRALLED	35	ROCKMASTER/13
H10044	10	WIRE SPIRALLED	44	ROCKMASTER/4SH
H10049	10	WIRE SPIRALLED	49	ROCKMASTER/15
H10066	10	WIRE SPIRALLED	66	GOLDENBLAST/PLUS
H10067	10	WIRE SPIRALLED	67	GOLDENBLAST/SIX
H10072	10	WIRE SPIRALLED	72	GOLDENBLAST
H10086	10	WIRE SPIRALLED	86	SHIELDMASTER/6000 MINE
H10089	10	WIRE SPIRALLED	89	GOLDENISO/45 LONGLIFE
H10091	10	WIRE SPIRALLED	91	XTRAFLOW/4WS
H10093	10	WIRE SPIRALLED	93	GOLDENISO/21 XTRAFLEX
H10095	10	WIRE SPIRALLED	95	GOLDENISO/28 XTRAFLEX
H10096	10	WIRE SPIRALLED	96	GOLDENISO/35 XTRAFLEX
H10097	10	WIRE SPIRALLED	97	GOLDENISO/42 XTRAFLEX
H10098	10	WIRE SPIRALLED	98	GOLDENISO/38 LONGLIFE
H10102	10	WIRE SPIRALLED	102	DIAMONDSPIR/21
H10103	10	WIRE SPIRALLED	103	DIAMONDSPIR/35
H10104	10	WIRE SPIRALLED	104	DIAMONDSPIR/14
H10108	10	WIRE SPIRALLED	108	GOLDENISO/50 DIAMOND
H10109	10	WIRE SPIRALLED	109	GOLDENISO/56 DIAMOND
H10113	10	WIRE SPIRALLED	113	SHIELDMASTER/17 WS
H10119	10	"WIRE BRAIDED; WIRE SPIRALLED"	119	SHIELDMASTER/35
H10120	10	"WIRE BRAIDED; WIRE SPIRALLED"	120	SHIELDMASTER/42
H10125	10	WIRE SPIRALLED	125	HERCULES/HT
H10132	10	WIRE SPIRALLED	132	ANACONDA
H10133	10	WIRE SPIRALLED	133	FOREMASTER/35
H10134	10	WIRE SPIRALLED	134	FOREMASTER/42
H30005	30	TEXTILE, HELIX WIRE	5	SPIRTEX/K
H30010	30	THERMOPLASTIC	10	HYDROPLAST
H30011	30	THERMOPLASTIC	11	HYDROTWIN



FERRULES

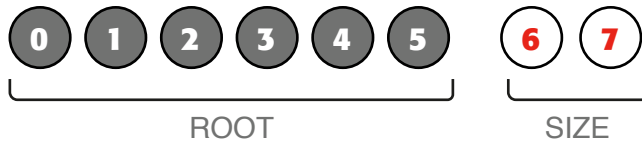

Value	Ferrule Type
M	Ferrule MF2000
C	Ferrule or clamp A/C
K	Reusable ferrule



Value	Description
0	Always



Refer to Ferrule Series table



Value	Issue of Ferrule
0	First issue of ferrule series
1	Second issue of ferrule series
2	Third issue of ferrule series
3	Fourth issue of ferrule series



Value	Special
0	Standard
1	Customised version
2	Customised version
...	...

## FERRULES (CONTINUED)

DIGITS "6-7"



Hose bore size

## FERRULE SERIES

DIGITS	DESCRIPTION
1	SKIVE FERRULE FOR W.B HOSES
3	NO-SKIVE FERRULE FOR TEXTILE BRAIDED HOSES / STAR-CRIMP FERRULE AC FOR REFRISTAR
4	REUSABLE STAR-FIT FERRULE AC FOR REFRISTAR
7	REFRIMASTER FERRULE AC
8	NO-SKIVE FERRULE FOR COMPACT HOSES
9	SKIVE FERRULE FOR W.B AND W.S HOSES
10	REFRIMASTER CLAMP
13	DOUBLE SKIVE FERRULE FOR H.D. SPIRAL HOSES (INTERLOCK 4-6 PLY)
14	DOUBLE SKIVE FERRULE FOR H.D. SPIRAL HOSES (INTERLOCK 4 PLY)
15	DOUBLE SKIVE FERRULE FOR H.D. SPIRAL HOSES (INTERLOCK PLUS 4 PLY)
16	DOUBLE SKIVE FERRULE FOR H.D. SPIRAL HOSES (INTERLOCK PLUS 6 PLY)
17	DOUBLE SKIVE FERRULE FOR EXTRA DUTY SPIRAL HOSES (BLASTLOCK-XTRALOCK 4 PLY)
18	DOUBLE SKIVE FERRULE FOR EXTRA DUTY SPIRAL HOSES (BLASTLOCK-XTRALOCK 6 PLY)
19	
24	NO-SKIVE FERRULE FOR MINIFIT
26	DOUBLE SKIVE FERRULE FOR EXTRA DUTY SPIRAL HOSES (INTERLOCK SUPER)
28	DOUBLE SKIVE FERRULE FOR EXTRA DUTY SPIRAL HOSES (INTERLOCK SUPER)
31	NO-SKIVE FERRULE FOR 1 W.B. HOSES
33	NO-SKIVE FERRULE FOR W.B. HOSES
34	NO-SKIVE FERRULE FOR W.B. HOSES
35	
54	NO-SKIVE FERRULE FOR 4 W.S. - 2 W.B. HOSES (SPIRALFIT)
55	NO-SKIVE FERRULE FOR 4 W.S. - 6 W.S. HOSES (SPIRALFIT)
90	FRIGOSTAR CLAMP

**TWO-PIECE HYDRAULIC FITTINGS**



Value	Description
M	MF2000 Connector (Multifit, Interlock, Xtralock, ...)
O	Accessories (banjo, flange clamps, bolt, ...)
L	Push-Lock Connector



Value	Description
1	Male or Double connector type Multifit
2	Female or Flange type Multifit
3	Male or Double connector type Interlock and Interlock Plus
4	Female or Flange type Interlock and Interlock Plus
5	Male or Double connector type Blastlock
6	Female or Flange type Blastlock
7	Male or Double connector type Spiralfit
8	Female or Flange type Spiralfit / Accessories (flange clamps and bolt)
A	Male or Double connector type Interlock Super
B	Female or Flange type Interlock Super
S	Female type Minifit
T	Male type Minifit



The numbers in these positions specify the termination end or the second tail.

See "Termination Ends Type" table for coding details.

## TWO-PIECE HYDRAULIC FITTINGS (CONTINUED)

## DIGIT "4"



Value	Bending Angle
0	Special Bending Angle
1	Straight
2	22,5° Swept
3	30° Swept
4	45° Swept
5	Double connector
6	60° Swept
7	67,5° Swept
8	Compact type
9	90° Swept

## DIGIT "5"



Value	Description
0	No Nut / Male / Double skive Flange type Interlock/InterlockPlus/Xtralock
1	Crimped-back Nut / No-skive or External-skive Flange type Multifit/Spiralfit
2	Thrust-wire Nut
3	Slip-on Nut
4	Double Thrust-wire Nut
7	One-piece flange clamp (only for O8... Codes)
8	ISO/SAE code 61 split flange clamp (only for O8... Codes)
9	ISO/SAE code 62 split flange clamp (only for O8... Codes)

## DIGITS "6-7"



Tail size

## DIGITS "8-9"



Termination end size

## DIGITS "10-11-12"



These digits specify various customisations related to dimensions, threads, drops, ...

**ONE-PIECE HYDRAULIC FITTINGS**



Value	Description
<b>OPK</b>	One-Piece (MF3000) No Skive Kompact
<b>OPF</b>	One-Piece (MF3000) No Skive Flat



Value	Description
<b>1</b>	Male
<b>2</b>	Female or Flange type



The numbers in these positions specify the termination end or the second tail.  
 See "Termination Ends Type" table for coding details.



Value	Bending Angle
<b>0</b>	Special Bending Angle
<b>1</b>	Straight
<b>2</b>	22,5° Swept
<b>3</b>	30° Swept
<b>5</b>	45° Swept
<b>6</b>	60° Swept
<b>7</b>	67,5° Swept
<b>8</b>	Compact type
<b>9</b>	90° Swept

ONE-PIECE HYDRAULIC FITTINGS (CONTINUED)



Value	Description
0	Flange type Interlock/Xtralock/Multispiral or Male
1	Crimped-back Nut or Flange type Multifit
2	Thrust-wire Nut
3	Slip-on Nut



Tail size



Termination end size



These digits specify various customisations related to dimensions, threads, drops, ...

## TERMINATION END TYPES

DIGIT	FITTINGS	Q.SAFE	DESCRIPTION (MALE END)	DESCRIPTION (FEMALE END)
00	00	-	DOUBLE CONNECTOR (SAME TAIL IN TWO-ENDS CONNECTORS) / NO END (PLUG)	NO END (PLUG)
01	-	01	BSP MALE DIN 3852-11 - ISO 1179-2 HEAVY DUTY "FORM E"	FIXED FEMALE GAS JIS B 2351 "TYPE O"
02	-	02	BSP MALE TAPERED THREAD LONG	BSP FEMALE TAPERED
03	03		BSP MALE PARALLEL THREAD O'R FLAT FACE (ISO 1179-3)	BSP BANJO
04	-	04	BSP MALE BULKHEAD	BSP FIXED FEMALE DIN 3852-2 "FORM X" / ISO 1179-1
05	05	05	BSP MALE 60° CONE SEAT BS5200 / ISO 8434-6	BSP FEMALE 60° CONE BS5200 / ISO 8434-6
06	06	-	BSP MALE FLAT FACE	BSP FEMALE FLAT SEAT
07	07	-	BSPT MALE	JIS B 8363 (BSP - NISSAN) SWIVEL FEMALE
08	08	08	METRIC BOLT DIN 7643	BSP O-RING FEMALE 60° CONE BS5200 / ISO 8434-6
09	09	-	BSP MALE O'RING BOSS ADJUSTABLE ISO 1179-3	METRIC BANJO DIN 7642
10	10	-	METRIC MALE 60° CONE SUPERLIGHT DIN 3863	METRIC FEMALE 60° CONE SUPERLIGHT DIN 3863
11	11	11	METRIC MALE 24° CONE SEAT LIGHT TYPE DIN 3861 / ISO 8434-1	-
12	12	12	METRIC MALE 24° CONE SEAT HEAVY TYPE DIN 3861 / ISO 8434-1	METRIC FEMALE 24° CONE O'RING HEAVY TYPE DIN 3865 / ISO 8434-1 LONG DROP
13	13	-	-	METRIC FEMALE MULTISEAL CONE DIN 3868
14		14	METRIC MALE DIN 3852-11 "FORM E" B/ ISO 9974-2	METRIC FIXED FEMALE DIN 3852-1 "FORM X" AND "FORM Y"
15	15	-	-	METRIC FEMALE 24° CONE O'RING LIGHT TYPE DIN 3865 / ISO 8434-1
16	16	-	-	METRIC FEMALE 24° CONE O'RING HEAVY TYPE DIN 3865 / ISO 8434-1
17	17	-	FRENCH MILLIMETRIC METRIC MALE 24° CONE SEAT	FRENCH MILLIMETRIC METRIC FEMALE
18	18	-	FRENCH GAZ METRIC MALE 24° CONE SEAT	FRENCH GAZ METRIC FEMALE
19	-	19	METRIC MALE (ADJUSTABLE + NON-ADJUSTABLE HEAVY) ISO 6149-2	METRIC FIXED FEMALE ISO 6149-1
20	20	-	-	DIN METRIC STANDPIPE L.T. DIN 2353
21	21	-	-	DIN METRIC STANDPIPE H.T. DIN 2353
23	-	23	JIC BULKHEAD MALE 37° CONE ISO 8434-2 / SAE J514	-
24	24	24	ORFS MALE ISO 8434-3 / SAE J1453	ORFS FEMALE ISO 8434-3 / SAE J1453
25	25	25	JIC MALE (37° CONE) ISO 8434-2 / SAE J514	JIC FEMALE (37° CONE SEAT) ISO 8434-2 / SAE J514
26	26	-	-	SAE FEMALE (45° CONE SEAT) SAE J512
27	27	27	ORFS BULKHEAD MALE ISO 8434-3 / SAE J1453	JIC FEMALE DOUBLE HEXAGON 37° CONE SEAT
28	28	28	NPTF MALE 60° CONE SEAT SAE J476A	NPSM SWIVEL FEMALE 60° CONE SAE J514
30	30	30	MALE O'RING BOSS TYPE SAE J1926-3	FEMALE PORT SAE J1926-1

## TERMINATION END TYPES (CONTINUED)

DIGIT	FITTINGS	Q.SAFE	DESCRIPTION (MALE END)	DESCRIPTION (FEMALE END)
32	-	32	MALE O-RING BOSS (ADJUSTABLE + NON-ADJUSTABLE HEAVY) SAE J1926-2	-
33	33	-	FLANGE HEAD (NOT INCLUDING CLAMPS) CODE 61 WITHOUT O-RING (ADAPTERS)	FLANGE ISO/SAE 61 (ISO 6162-1 / SAE J518 CODE 61)
34	34	34	API MALE	NPTF FIXED FEMALE SAE J476A
35	35	-	NPT MALE	NPT FIXED FEMALE
36	36	-	FLANGE HEAD (NOT INCLUDING CLAMPS) CODE 62 WITHOUT O-RING (ADAPTERS)	FLANGE ISO/SAE 62 (ISO 6162-2 / SAE J518 CODE 62)
37	37	37	METRIC MALE 60° CONE SUPERLIGHT DIN 3863 BULKHEAD	FLANGE ISO/SAE 62 PLUS / FLANGE (A/C)
38	38	-	JIS B8363 TOYOTA MALE	JIS B 8363 (TOYOTA) SWIVEL FEMALE
39	39	-	JIS MALE O-RING BOSS - JIS B 8363 TYPE CO	SUPERCAT FLANGE
40	40	-	KOMATSU METRIC MALE 60° CONE SEAT	JIS B 8363 (KOMATSU) SWIVEL FEMALE
41	41	-	NPTF SWIVEL MALE SAE J476A	KOMATSU FLANGE
43	43	-	SAE O-RING BOSS SWIVEL MALE	-
44	44	-	-	ORFS FEMALE LONG DROP ELBOW ISO 12151-1 / SAE
47	47	-	-	JIC (37° CONE) FEMALE LONG DROP ELBOW ISO 12151-5 / SAE J516
49	49	-	-	WASH CLEANING
55	55	-	BSP PARALLEL THREAD 60° CONE BS5200 (ONLY FOR BLASTLOCK TAIL)	BSP PARALLEL THREAD 60° CONE BS5200 (ONLY FOR BLASTLOCK TAIL)
66	66	-	-	METRIC FEMALE 24° CONE O-RING HEAVY TYPE DIN 3865 / ISO 8434-2 (ONLY FOR BLASTLOCK)
77	-	77	DIN BULKHEAD MALE 24° CONE LIGHT TYPE ISO 8434-1	-
78	78	-	NPTF MALE 60° CONE SEAT SAE J476A (ONLY FOR BLASTLOCK)	-
84	84	-	-	XTRAFLLANGE/61 (ISO6162-1 / SAE J518 CODE 61 PORT COMPATIBLE)
85	85	-	-	XTRAFLLANGE/62 (ISO 6162-2 / SAE J518 CODE 62 PORT COMPATIBLE)
95	95	-	BRAZING PIPE (FITTINGS)	BRAZING SOCKET (FITTINGS) / BEVELED TO WELD (ONLY DRILLING)



## TERMINATION END TYPES (CONTINUED)

DIGITS	EASY-FIT / FAST-FIT
2H	EASY-FIT HIGH PRESSURE (OEJN)
3H	FAST-FIT

DIGITS	ACCESSORIES FOR CONNECTORS (08...)
02	BSP BOLT
08	METRIC BOLT DIN 7643
20	ANTI-KINK SLEEVE
21	METAL SLEEVE
33	CLAMPS FOR FLANGE ISO/SAE 61
36	CLAMPS FOR FLANGE ISO/SAE 62
42	ARMOUR - JOINT
84	XTRAFLLANGE/61 CLAMPS
85	XTRAFLLANGE/62 CLAMPS
2H	CARTRIDGE FOR EASY-FIT HIGH PRESSURE

HYDRAULIC QUICK COUPLINGS

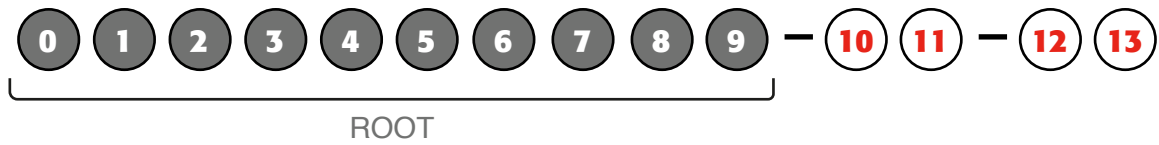

**Value**                      **Description**

Q	Quick Coupling
---	----------------



**Value**                      **Description**

0	Hydraulic
---	-----------



Quick Coupling Series - refer to "Quick Coupling Series" table



**Value**                      **Material**

1	Steel
2	AISI 316
3	AISI 303
4	Brass
5	Aluminium

HYDRAULIC QUICK COUPLINGS (CONTINUED)



Value	Seal Material
0	None
1	NBR (Nitrile)
2	HNBR
3	FKM (Viton, FPM)
4	CR (Neoprene)
5	EPDM
6	FFPM (Kalrez)
7	NBR - Low Temperature
8	VMQ (Silicone Rubber)
9	AU (Polyurethane)
A	PTFE



The numbers in these positions specify the termination end.  
See "Termination Ends Type" table for coding details.



Value	Description
0	Male
1	Female



A letter in this position indicates a customised version.



The numbers in this position indicate the Quick Coupling size.



The numbers in this position indicate the thread size.

HYDRAULIC QUICK COUPLING TAILS

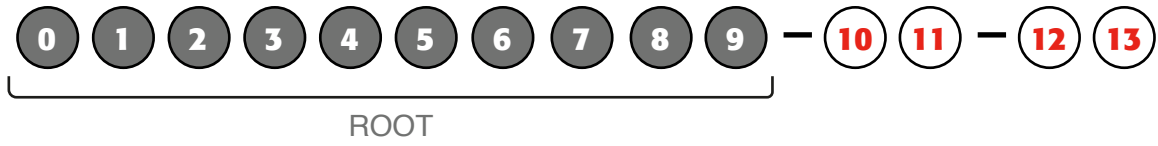

Value	Description
Q	Quick Coupling



Value	Description
3	Q.Tail



Quick Coupling Series - refer to "Quick Coupling Series" table



Value	Material
1	Steel
2	AISI 316
3	AISI 303
4	Brass
5	Aluminium

HYDRAULIC QUICK COUPLING TAILS (CONTINUED)

**DIGIT "5"** (0) (1) (2) (3) (4) (5) (6) (7) (8) (9) – (10) (11) – (12) (13)

Value	Seal Material
0	None
1	NBR (Nitrile)
2	HNBR
3	FKM (Viton, FPM)
4	CR (Neoprene)
5	EPDM
6	FFPM (Kalrez)
7	NBR - Low Temperature
8	VMQ (Silicone Rubber)
9	AU (Polyurethane)

**DIGIT "6-7"** (0) (1) (2) (3) (4) (5) (6) (7) (8) (9) – (10) (11) – (12) (13)

Value	Insert Type
MF	Multifit type

**DIGIT "8"** (0) (1) (2) (3) (4) (5) (6) (7) (8) (9) – (10) (11) – (12) (13)

Value	Insert Angle
1	Straight

**DIGIT "9"** (0) (1) (2) (3) (4) (5) (6) (7) (8) (9) – (10) (11) – (12) (13)

A letter in this position indicates a customised version.

**DIGITS "10-11"** (0) (1) (2) (3) (4) (5) (6) (7) (8) (9) – (10) (11) – (12) (13)

The numbers in this position indicate the Quick Coupling size.

**DIGITS "12-13"** (0) (1) (2) (3) (4) (5) (6) (7) (8) (9) – (10) (11) – (12) (13)

The numbers in this position indicate the Insert size.

HYDRAULIC QUICK COUPLING PLUGS, SEALS & CARTRIDGES

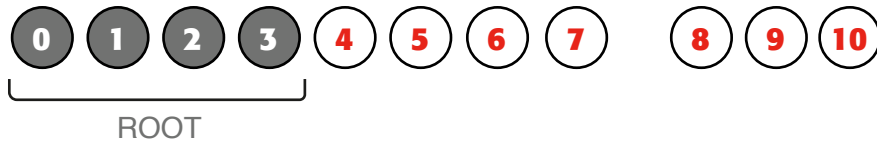

**DIGIT "0"**



**Value**                      **Description**

Q	Quick Coupling
---	----------------

**DIGIT "1"**



**Value**                      **Description**

1	Plugs and Seals
---	-----------------

**DIGITS "2-3"**



Quick Coupling Series - refer to "Quick Coupling Series" table

**DIGIT "4"**



**Value**                      **Material**

0	None
1	Steel
2	AISI 316
3	AISI 303
4	Brass
5	Aluminium
A	PE (polyethylene)
B	PVC
C	PA (polyamide)
D	POM (acetalic resin)

HYDRAULIC QUICK COUPLING PLUGS, SEALS & CARTRIDGES (CONTINUED)

**DIGIT "5"**



Value	Seal Material
0	None
1	NBR (Nitrile)
2	HNBR
3	FKM (Viton, FPM)
4	CR (Neoprene)
5	EPDM
6	FFPM (Kalrez)
7	PTFE
8	VMQ (Silicone Rubber)
9	AU (Polyurethane)

**DIGIT "6"**



Value	Function
0	Simple cap / plug
1	EcoCap (with oil recycle)
2	Automatic cap
3	Seal
4	Parking
5	Cartridge

**DIGIT "7"**



Value	Colour
N	Not specified or natural
R	Red
B	Blue
Y	Yellow
G	Green
K	Black
W	Brown
H	White
O	Orange
E	Grey

## HYDRAULIC QUICK COUPLING PLUGS, SEALS &amp; CARTRIDGES (CONTINUED)

## DIGITS "8-9"



Quick coupling size - corresponds to nominal internal hose diameter recommended for use with the coupling (see ISO 4397)

## DIGIT "10"



Free digit for Version or other.



## HYDRAULIC QUICK COUPLING SERIES

QC SERIES	PLUG & SEALS SERIES	DESCRIPTION	
01	A0	MALE ACCORDING TO ISO 7241-1 STANDARDS, SERIES A	FREE FLOW
02		MALE ACCORDING TO ISO 7241-1 STANDARDS, SERIES A	POPPET VALVE
03		MALE ACCORDING TO ISO 7241-1 STANDARDS, SERIES A	BALL VALVE
04		MALE ACCORDING TO ISO 7241-1 STANDARDS, SERIES A	POPPET VALVE, SPECIAL GUIDEVALVE
05		MALE ACCORDING TO ISO 7241-1 STANDARDS, SERIES A	BALL VALVE, SPECIAL GUIDEVALVE
06		MALE ACCORDING TO ISO 7241-1 STANDARDS, SERIES A	CONNECTABLE UNDER PRESSURE
07	A1	FEMALE ACCORDING TO ISO 7241-1 STANDARDS, SERIES A	FREE FLOW
08		FEMALE ACCORDING TO ISO 7241-1 STANDARDS, SERIES A	ONE-WAY RELEASE, POPPET VALVE
09		FEMALE ACCORDING TO ISO 7241-1 STANDARDS, SERIES A	ONE-WAY RELEASE, BALL VALVE
10		FEMALE ACCORDING TO ISO 7241-1 STANDARDS, SERIES A	ONE-WAY RELEASE, CONNECTABLE UNDER PRESSURE
11		FEMALE ACCORDING TO ISO 7241-1 STANDARDS, SERIES A	ONE-WAY RELEASE, CONNECTABLE WITH MALE UNDER PRESSURE
12		FEMALE ACCORDING TO ISO 7241-1 STANDARDS, SERIES A	ONE-WAY RELEASE, CONNECTABLE WITH BOTH PARTS UNDER PRESSURE
13		FEMALE ACCORDING TO ISO 7241-1 STANDARDS, SERIES A	TWO-WAYS RELEASE, POPPET VALVE
14		FEMALE ACCORDING TO ISO 7241-1 STANDARDS, SERIES A	TWO-WAYS RELEASE, BALL VALVE
15		FEMALE ACCORDING TO ISO 7241-1 STANDARDS, SERIES A	TWO-WAYS RELEASE, CONNECTABLE UNDER PRESSURE
16		FEMALE ACCORDING TO ISO 7241-1 STANDARDS, SERIES A	TWO-WAYS RELEASE, CONNECTABLE WITH MALE UNDER PRESSURE
17		FEMALE ACCORDING TO ISO 7241-1 STANDARDS, SERIES A	TWO-WAYS RELEASE, CONNECTABLE WITH BOTH PARTS UNDER PRESSURE
18		FEMALE ACCORDING TO ISO 7241-1 STANDARDS, SERIES A	RIGID, TWO-WAYS RELEASE, CONNECTABLE WITH MALE UNDER PRESSURE
19		FEMALE ACCORDING TO ISO 7241-1 STANDARDS, SERIES A	RIGID, TWO-WAYS RELEASE, CONNECTABLE WITH BOTH PARTS UNDER PRESSURE
20	A2	MALE ACCORDING TO ISO 7241-1 STANDARDS, SERIES B	FREE FLOW
21		MALE ACCORDING TO ISO 7241-1 STANDARDS, SERIES B	POPPET VALVE
22		MALE ACCORDING TO ISO 7241-1 STANDARDS, SERIES B	BALL VALVE
23	A3	FEMALE ACCORDING TO ISO 7241-1 STANDARDS, SERIES B	FREE FLOW
24		FEMALE ACCORDING TO ISO 7241-1 STANDARDS, SERIES B	ONE-WAY RELEASE, POPPET VALVE
25		FEMALE ACCORDING TO ISO 7241-1 STANDARDS, SERIES B	ONE-WAY RELEASE, BALL VALVE
26		FEMALE ACCORDING TO ISO 7241-1 STANDARDS, SERIES B	SAFETY SLEEVE, POPPET VALVE
27		FEMALE ACCORDING TO ISO 7241-1 STANDARDS, SERIES B	SAFETY SLEEVE, BALL VALVE
28	A4	MALE STANDARD SERIES	FREE FLOW
29		MALE STANDARD SERIES	POPPET VALVE
30		MALE STANDARD SERIES	BALL VALVE
31	A5	FEMALE STANDARD SERIES	FREE FLOW
32		FEMALE STANDARD SERIES	ONE-WAY RELEASE, POPPET VALVE
33		FEMALE STANDARD SERIES	ONE-WAY RELEASE, BALL VALVE
34		FEMALE STANDARD SERIES	SAFETY SLEEVE, POPPET VALVE

## HYDRAULIC QUICK COUPLING SERIES (CONTINUED)

QC SERIES	PLUG & SEALS SERIES	DESCRIPTION	
35	A5	FEMALE STANDARD SERIES	SAFETY SLEEVE, BALL VALVE
36		FEMALE STANDARD SERIES	TWO-WAYS RELEASE, POPPET VALVE
37	A6	COMPACT MALE	FREE FLOW
38	A7	COMPACT FEMALE	FREE FLOW
39	A8	FLAT FACE MALE ACCORDING TO ISO 16028	
40		FLAT FACE MALE ACCORDING TO ISO 16028	CONNECTABLE UNDER PRESSURE
41	A9	FLAT FACE FEMALE ACCORDING TO ISO 16028	WITH SAFETY SLEEVE
42		FLAT FACE FEMALE ACCORDING TO ISO 16028	WITHOUT SAFETY SLEEVE
43	A8	FLAT FACE MALE ACCORDING TO ISO 16028	WORKING PRESSURE 35MPA
44	A9	FLAT FACE FEMALE ACCORDING TO ISO 16028	WORKING PRESSURE 35MPA
45	AC	MALE FOR DIAGNOSTIC PURPOSE ACCORDING TO ISO 15171	
46	AD	FEMALE FOR DIAGNOSTIC PURPOSE ACCORDING TO ISO 15171	
47	AE	MALE FOR HYDRAULIC BRAKING CIRCUIT ACCORDING TO ISO 5676	
48	AF	FEMALE FOR HYDRAULIC BRAKING CIRCUIT ACCORDING TO ISO 5676	
49	AG	SCREW TYPE MALE FOR HYDRAULIC BRAKING CIRCUIT	
50	AH	SCREW TYPE FEMALE FOR HYDRAULIC BRAKING CIRCUIT	
51	AI	SCREW TYPE MALE FOR GERMAN MARKET	
52	AJ	SCREW TYPE FEMALE FOR GERMAN MARKET	
53	AK	SCREW TYPE MALE FOR VERY HIGH PRESSURE	
54	AL	SCREW TYPE FEMALE FOR VERY HIGH PRESSURE	
55	AM	SCREW TYPE MALE FOR HYDRAULIC CYLINDER	
56	AN	SCREW TYPE FEMALE FOR HYDRAULIC CYLINDER	
57	AP	SCREW TYPE MALE FOR TRUCK	
58	AQ	SCREW TYPE FEMALE FOR TRUCK	
59	AR	COMPACT FLAT FACE MALE SCREW TYPE	
60	AS	COMPACT FLAT FACE FEMALE SCREW TYPE	
61	AI	SCREW TYPE MALE FOR GERMAN MARKET	HEAVY DUTY
62	AJ	SCREW TYPE FEMALE FOR GERMAN MARKET	HEAVY DUTY
63	AT	SCREW TYPE MALE FOR U.S. MARKET	(NOT AVAILABLE IN OTHER MARKETS - NO CATALOGUE)
64	AU	SCREW TYPE FEMALE FOR U.S. MARKET	(NOT AVAILABLE IN OTHER MARKETS - NO CATALOGUE)
65	A1	FEMALE ACCORDING TO ISO 7241-1 STANDARD, SERIES A	RIGID, TWO WAYS RELEASE
66	AV	FLAT FACE MALE SCREW TYPE	
67	AW	FLAT FACE FEMALE SCREW TYPE	

**ASSEMBLY MACHINES**

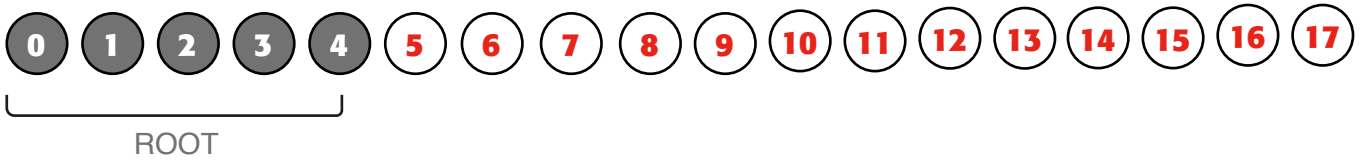

Value	Description
<b>E</b>	Always means "Equipment"



Value	Description
<b>O</b>	Assembly Machines
<b>S</b>	Spare Parts



The letter in this position identifies the equipment type.

Value	Equipment Type
<b>A</b>	Assembly
<b>C</b>	Cutting
<b>S</b>	Skiving
<b>L</b>	Cleaning
<b>M</b>	Marking
<b>I</b>	Insert Pushing
<b>T</b>	Test Bench
<b>F</b>	Flushing

## ASSEMBLY MACHINES (CONTINUED)

## DIGIT "3"



The number in this position identifies the supplier.

Value	Supplier
1	Finnpower
2	Uniflex
3	Techmafex
4	OP
5	Hydroscand

## DIGIT "4"



The number in this position identifies the platform.

Value	Platform
1	MRI 1 Portable machines
2	MRI 2 Small benchtop < 2" 2T
3	MRI 3 Benchtop for professional service >2" 2T
4	MRI 4 Production stand type machines
5	MRI 5 Top level stand type machines (Industrial, Special), eg. rotary hose crimper
6	MRI 6 Second hand machines

## DIGIT "5"



The number in this position identifies the version.

Value	Version
1	Basic MRI except for mobile machines ('V' machines)
2	Medium MRI 2 and MRI 3 (Benchtop)
3	Top MRI 4 and some MRI 5 (XL)
4	Top Bis MRI 5 sup, at 100t
5	Mobile 'V' machines (12V, 24V)

ASSEMBLY MACHINES (CONTINUED)



The number or letter in this position identifies the power system.

Value	Power System
0	Manual
1	12V
2	24V
3	220/240V 1PH 50HZ
4	380/415V 3PH 50HZ
5	110V 1PH 60 HZ
6	208/240V 3PH 60HZ (to be associated with code 9)
7	220/240V 3PH 50HZ
8	220/240V 1PH 60HZ
9	208/240V 3PH 60HZ
A	220/240V 1PH 50HZ
B	380/415V 3PH 60HZ
C	208/240V 3PH 60HZ
D	440V 3PH 50HZ
E	220/240V 1PH 60HZ
F	440/480V 3PH 60HZ
G	200V 3PH 50HZ
H	110V 1PH 50HZ
I	240V 1PH 50HZ
K	220/380/440V 3PH 50HZ
L	208V 1PH 60HZ



The letter in this position identifies the version.

Value	Description
S	Die sets included
N	Die sets not included



Free digits for special characteristics

HOSE PROTECTIONS

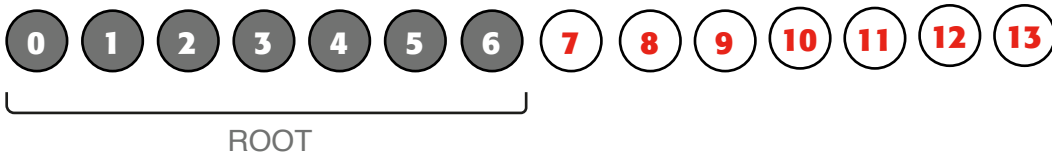

**DIGIT "0"**



**Value**                      **Description**

J	Always means "Accessories"
---	----------------------------

**DIGIT "1"**



**Value**                      **Description**

P	Always means "Protection"
---	---------------------------

**DIGIT "2"**



**Value**                      **Protection Type**

1	Spring
2	Sleeve
3	Clinch
4	Flexible armour

**DIGIT "3"**



**Value**                      **Material**

1	Polyethylene
2	Polyammide
3	Polyester
4	Silicone
5	Stainless steel
6	Steel

HOSE PROTECTIONS (CONTINUED)

**DIGIT "4"**      0   1   2   3   4   5   6   7   8   9   10   11   12   13

Value	Colour
B	Black
Y	Yellow
A	Orange
G	Grey
M	Metal
T	Other

**DIGITS "5-6"**      0   1   2   3   4   5   6   7   8   9   10   11   12   13

Value	Product Family
01	Protection spring
02	Mining protection spring
03	HT Protection spring
04	Light protection spring
05	Fire sleeve
06	Textile sleeve
07	Round metal sleeve
08	Heat protection spring
09	BOP hose flexible armour
10	Clinch

**DIGITS "7-8-9"**      0   1   2   3   4   5   6   7   8   9   10   11   12   13

The numbers in these positions indicate the internal diameter in mm.

HOSE PROTECTIONS (CONTINUED)

DIGITS "10-11-12-13"



Letters and numbers in these positions describe branding, packaging or special length information.

**Value                      Branding Information**

<b>E</b>	Embossed / Embedded
<b>I</b>	Inkjet
<b>T</b>	Textile

**Value                      Packaging Information**

<b>0</b>	Embossed/Embedded
----------	-------------------

**Value                      Branding**

<b>99</b>	Standard
-----------	----------



RING & SEAL

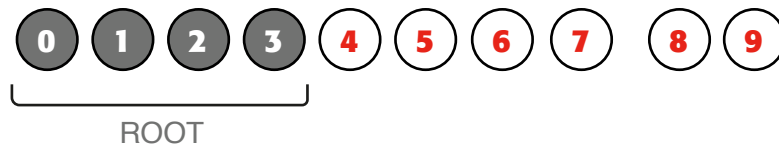

**DIGIT "0"**



Value	Description
J	Always means "Accessories"

**DIGIT "1"**



Value	Description
0	Always means "Rings"

**DIGITS "2-3"**



Value	Description	Value	Description
01	O'ring for SAE 3000 and 6000 PSI flange	17	Kit copper sealing rings
02	O'ring imperial size	18	Kit O'ring metric size
03	O'ring metric size	19	O'ring for ORFS
04	O'ring for Staple Lock	20	O'ring for H.P washer fitting
05	O'ring for MSAE	21	O'ring for refri fitting
06	O'ring and metallic anti-extrusion ring for metric series	22	Cylindrical seal for refri connector
07	O'ring for BSPP	23	O'ring for Super Staple Lock
08	Metallic anti-extrusion ring for male BSPP	24	Metal sealing ring for banjos
09	O'ring for ETCAO	25	Metal sealing ring for pressure gauge connectors
10	Flat seal built in	26	Soft sealing ring for banjos
11	Copper sealing ring	27	Elastomeric (captive) seal - NBR
12	Bonded seal ring	28	Elastomeric (captive) seal - Viton
13	Flange counter-ring for "Caterpillar" insert	29	Interlock Plus O-Ring
14	Seal type for SAE 3000 and 6000 PSI flange	30	One-piece Polyurethane seal for Staple Low Pressure (Yellow)
15	Support plastic ring (open ring)	31	One-Piece Polyurethane seal for Staple High Pressure (Red)
16	kit bonded seal rings		

## RING &amp; SEAL (CONTINUED)

## DIGITS "4-5"



The numbers in these positions indicate the external diameter in mm.

## DIGITS "6-7"



The numbers in these positions indicate the internal diameter in mm.

## DIGITS "8-9"



The numbers in these positions indicate the axial thickness in mm.

INCORRECT USE

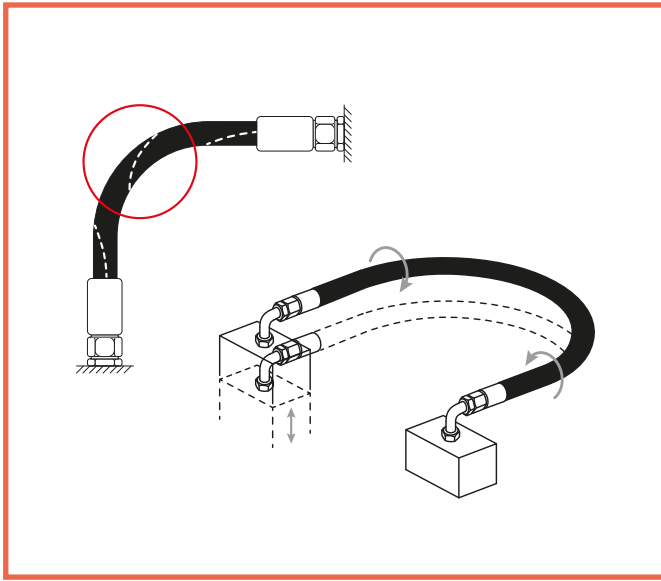

CORRECT USE

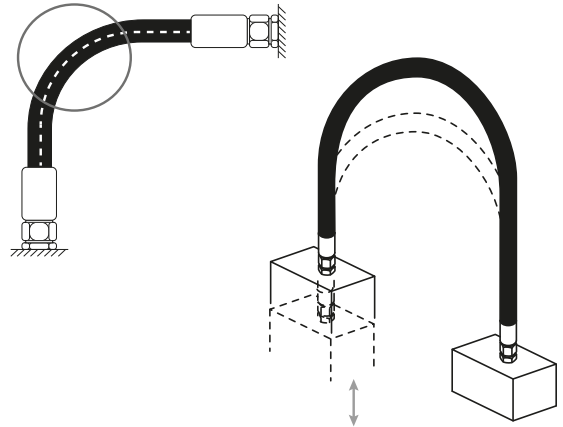

- Avoid twisting the hose assembly when installing.
- Avoid situations where moving parts will cause twisting effects on the hose assemblies after installation.

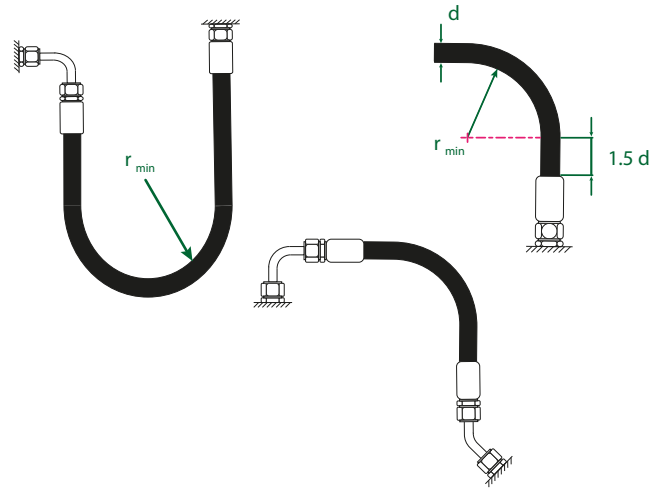
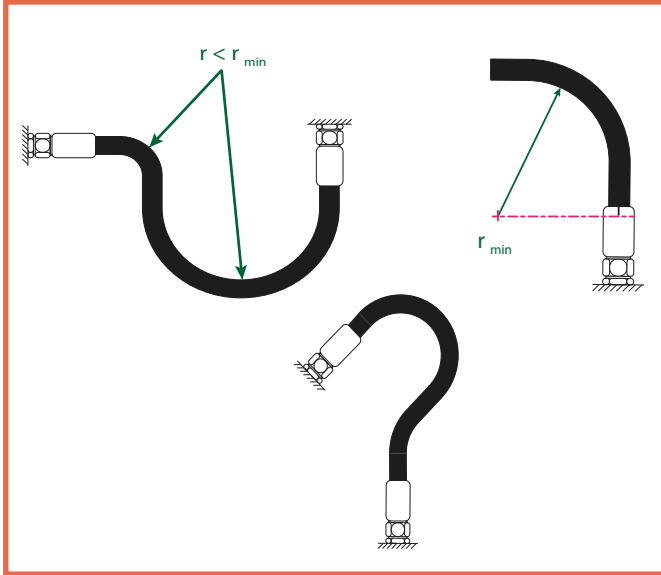

- Select the correct fittings to avoid tight bend radii.
- Ensure a minimum distance of 1.5 x "d" after the ferrule before hose bending.

**INCORRECT USE**

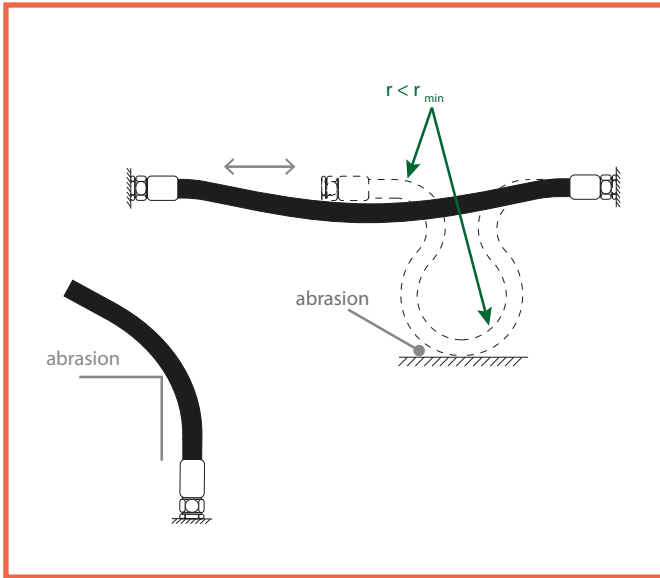

**CORRECT USE**

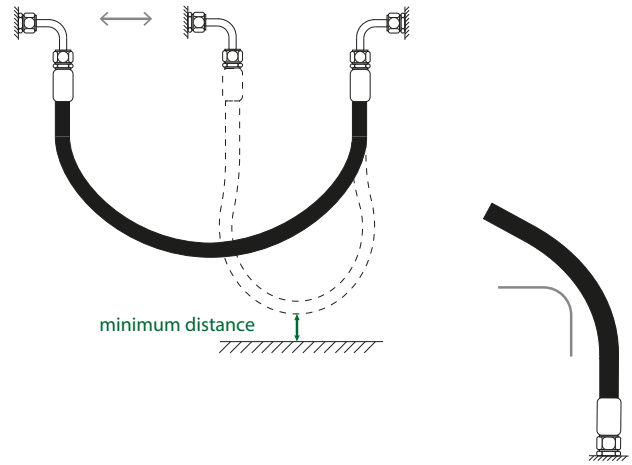

- Avoid interference with objects that can cause abrasion or damage to the hose.
- In flexing applications ensure that the hose is not subjected to tensile stresses or to impacts / abrasion from the surrounding environment.

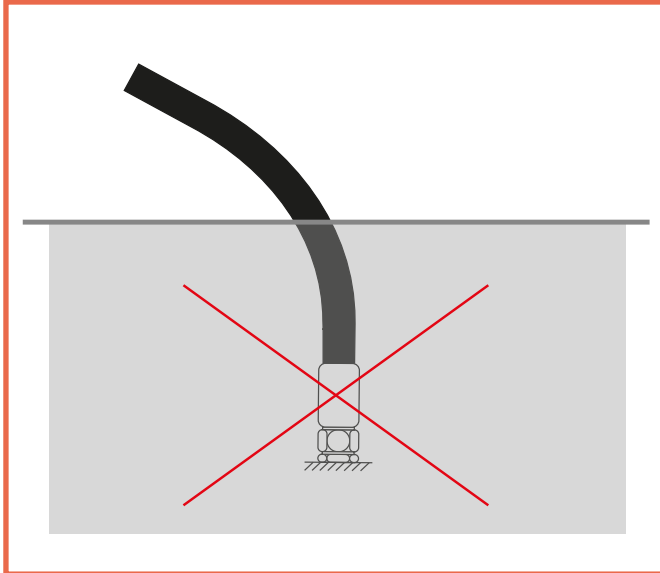

The Manuli hydraulic hose product range is not designed for immersion in the service fluid. This type of special application should be avoided or carefully studied with reference to the hose specifications

For detailed information concerning recommended practices for hydraulic hose assemblies, please refer to **SAE J1273** and **ISO/TS 17165-2**. This document should be used as a guide when selecting, routing, fabricating, installing, replacing, maintaining and storing hose for hydraulic systems.

### PRODUCT SELECTION AND INSTALLATION

The information in this document concerning hoses, fittings and other items manufactured and provided by Manuli Rubber Industries and its subsidiaries, is provided for the express purpose of aiding in the correct selection of products for particular applications. However it is the responsibility of the customer to ensure that they consider the specific details of the application during the selection process.

Important factors to consider include:

- Hose size
- Hose length
- Fluid compatibility
- Ambient and operating temperatures
- System operating pressures
- Static head pressures
- Installation design
- Minimum bend radii
- Possible abrasion of the hose
- Movement and flexing of the hose during operation

Improper selection and / or installation of hydraulic hose assemblies can result in reduced assembly life, equipment failure, property damage, bodily injury or death.

### HOSE INTEGRATION

Manuli hoses and fittings are designed to be part of an integrated hose assembly system. As such they should only be used together or in conjunction with other types of fittings recommended by Manuli Rubber Industries and its subsidiaries. Failure to observe these requirements may result in a reduced lifespan of the hose assemblies or other failures which can cause equipment failure, property damage, bodily injury or death.

Manuli provides guidelines for the proper assembly, installation, maintenance and use of its products and further information on recommended practices is available in [SAE J1273](#) and [ISO/TS 17165-2](#).

Should you have any questions regarding proper assembly, installation or application usage of any Manuli product, please contact our Technical Centre in Italy.

### WARNING!

**Improper selection or use of any of the products found in this document may result in property damage, bodily injury or death. Consider all aspects of your application carefully to ensure that the products selected are the most appropriate for the task.**

Manuli Rubber Industries reserves the right to modify the data provided in this catalogue without notice.

© Copyright 2019 Manuli Rubber Industries S.p.A. All rights reserved.

No part of this document may be reproduced or transmitted, in any form or by any means, without the express written permission of Manuli Rubber Industries.